

CONTENTS

Click on any title in the Contents table below to access the relevant section.

1.	THE eCAFÉ™ – TAKE IT TO GO!	2
1.1	Handling your netbook	2
1.2	A comprehensive package	2
1.3	A closer look at your eCAFÉ™	3
2.	eCAFÉ™ – UNEQUALLED AND UNRIVALLED	4
2.1	My eCAFÉ™	4
2.2	Multifunction keyboard	6
2.3	A netbook suited to large files	7
2.4	Extensive connectivity options for countless applications	7
2.5	A desktop device AND a mobile device	9
2.5.1	Operating the eCAFÉ™ when connected to the mains	9
2.5.2	Operating the eCAFÉ™ with the built-in battery	9
2.5.3	Installing and removing the battery	10
2.5.4	Optimising your use of the battery	12
3.	FIRST STEPS WITH MY eCAFÉ™	13
3.1	Turning the eCAFÉ™ On/Off	13
3.2	Connecting an external display	14
3.3	Connecting a keyboard and a mouse	15
3.4	Connecting headphones and a microphone	15
3.5	Mastering the touchpad	16
3.6	Accessing the help interface	17
3.7	Welcome to the eCAFÉ™ galaxy!	17
3.7.1	All the essentials in just one click	17
3.7.2	Extensive contents to take you further	22
3.8	Adjusting the main settings	24
3.8.1	eCAFÉ™ Connect and the WiFi feature	24
3.8.2	Date and time	25
3.8.3	Language	25
3.8.4	Volume	25
3.8.5	Printers	25
3.9	Customising your world	26
3.9.1	Defining user profiles	26
3.9.2	Customising the interface's appearance	26
4.	COMMUNICATIONS	27
4.1	Connecting to the Internet	27
4.1.1	...using the WiFi feature	27
4.1.2	...via a DSL connection or a local area network	30
4.2	Sending and receiving emails	30
4.3	Chatting with friends	35
5.	GAMES	38
6.	MULTIMEDIA	39
6.1	Viewing and organising your photos	40
6.2	Viewing videos	41
6.3	Listening to music	42
6.4	Using the webcam	44
7.	WORK	45
7.1	Creating, editing, saving and more	45
7.1.1	...A document using OpenOffice.org Writer (word processor)	46
7.1.2	...A spreadsheet using OpenOffice.org Calc (spreadsheet program)	47
7.1.3	...A slideshow using OpenOffice.org Impress (slideshow creator)	49
7.2	Managing your bank accounts	54
7.3	Managing your schedule	55
8.	INSTALLING APPLICATIONS	56
9.	SAVING AND RESTORING DATA	57
9.1	Creating backups on a USB key	57
9.2	Creating backups on a memory card	57
9.3	Creating backups on a CD or DVD	57
9.4	Restoring backup data from a USB key	57
9.5	Restoring backup data from a memory card	58
9.6	Restoring backup data from CD or DVD	58
	INDEX	59
	WARNING	60
	Always observe the following recommendations when playing video games	60
	About photosensitive epileptic seizures	60
	TECHNICAL SUPPORT	61
	WARRANTY INFORMATION	61

1. THE eCAFÉ™ – TAKE IT TO GO!

Thank you for trusting Hercules by choosing to purchase the eCAFÉ™ netbook. The eCAFÉ™ has been designed to allow you to communicate and create or edit documents such as text files, slideshows or even images; it also includes advanced multimedia features designed to entertain you.

To make the most of your eCAFÉ™ netbook, please follow the instructions provided in this manual.



A number of operations that you can perform on your eCAFÉ™ will require you to provide a password. The default user account password is "ec-900", and the administration account password is "root".

You can change these passwords in the **Security** thumbnail of the **Computer Configuration** application.

1.1 Handling your netbook



Please read this section with care before using the product.

Like any electronic device, the eCAFÉ™ requires you to observe a number of simple safety rules; these are listed below. In addition, observing some simple precautions will enable you to extend your eCAFÉ™'s life.

- In no circumstance should you attempt to open the eCAFÉ™, its adaptor or its components; doing this would expose the device's internal components to damage. Likewise, never attempt to open the device's batteries.
- Use only the adaptor provided with the product.
- Always place your eCAFÉ™ on a horizontal, stable and flat surface.
- Never exert pressure on the display. Never touch the display with any objects that are liable to damage it or scratch it.
- Always make sure that you have removed any objects placed on the device's keyboard (e.g. USB key, pen or others) before closing your eCAFÉ™'s display.
- To avoid any risk of fire or electric shock, always keep your eCAFÉ™ away from:
 - Rain or moisture, as well as all fluids (water, chemical products and any other liquids),
 - Heat sources such as radiators, cookers or other heat-emitting devices (including amplifiers),
 - Direct sunlight.
- This product should be used only at temperatures ranging from 5 to 35°C.
- Never cover your eCAFÉ™ while the device is powered on.
- Always unplug your eCAFÉ™ before cleaning it. To clean it, use a soft cloth; avoid using chemical sprays.
- The eCAFÉ™ provides a WiFi wireless connection feature. Use of this feature is liable to cause interferences with the equipment located on planes or in hospitals. Always deactivate this feature before entering these premises.
- Always deactivate the WiFi feature during thunderstorms.
- Never throw the device's batteries into an open fire.
- When transporting the eCAFÉ™, always turn the device off if you are carrying it in a closed bag. As a general rule, make sure that your eCAFÉ™ is placed in a well-vented environment when the device is powered on.

1.2 A comprehensive package

Compact design, an ultra-lightweight device, powerful connectivity, various accessories included. Discover the packaging contents:

- eCAFÉ™ personal computer
- Battery
- Power adaptor
- Quickstart guide

1.3 A closer look at your eCAFÉ™

- 1.6 GHZ Intel® ATOM™ Processor
- 512 MB DDR2 (SO-DIMM) RAM
- 8.9" backlit LCD screen (max. resolution: 1024 x 600 native)
- Built-in 1,300,000-pixel webcam, built-in microphone
- Built-in Intel® 945GSE video card, built-in sound card
- Built-in WiFi 802.11 b/g/N card
- 1.8" 60 GB PATA/ZIF hard drive
- Rechargeable 6000 mAh (6-cell) lithium battery
- 100–240 V, 50/60 HZ mains adaptor
- 3 USB 2.0 ports (compatible with USB 1.1 devices)
- 1 10/100 MBps Ethernet port
- 1 VGA outlet
- 1 headphone input, 1 microphone input
- 80-key keyboard
- Touchpad with 2 buttons
- Multi-format memory card drive for (Secure Digital), SD HC (Secure Digital HC), MMC (MultiMedia Card)
- Weight: less than 1.2 kg with the battery
- Dimensions: 225 mm x 168 mm x 33 mm

The included operating system is specific to your eCAFÉ™. It is based on the latest Linux Mandriva operating system, and includes all the essential applications you may require to use your netbook at home or "on the road". It can however be extended via the "Computer Configuration" application.

2. eCAFÉ™ – UNEQUALLED AND UNRIVALLED

The eCAFÉ™ netbook features a very wide range of applications and extensive connectivity interfaces, which will enable you to instantly connect to the world that is best suited to your use: work, communications, games or multimedia.

2.1 My eCAFÉ™

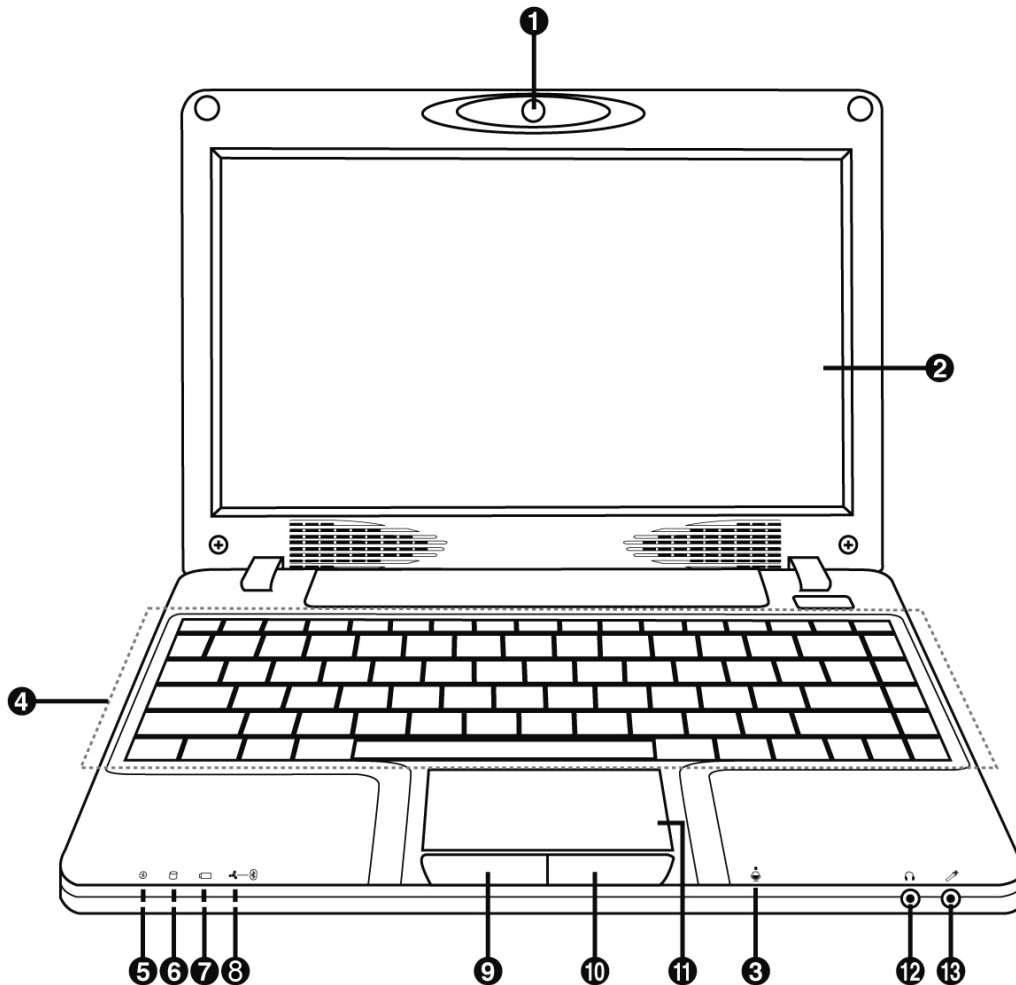

- | | | |
|--------------------------------------|--|----------------------|
| 1. Webcam | 6. Hard drive activity indicator light | 10. Right button |
| 2. 8.9" LCD screen | 7. Battery usage indicator light | 11. Touchpad |
| 3. Microphone | 8. WiFi indicator light | 12. Headphone input |
| 4. English keyboard | 9. Left button | 13. Microphone input |
| 5. Mains power usage indicator light | | |

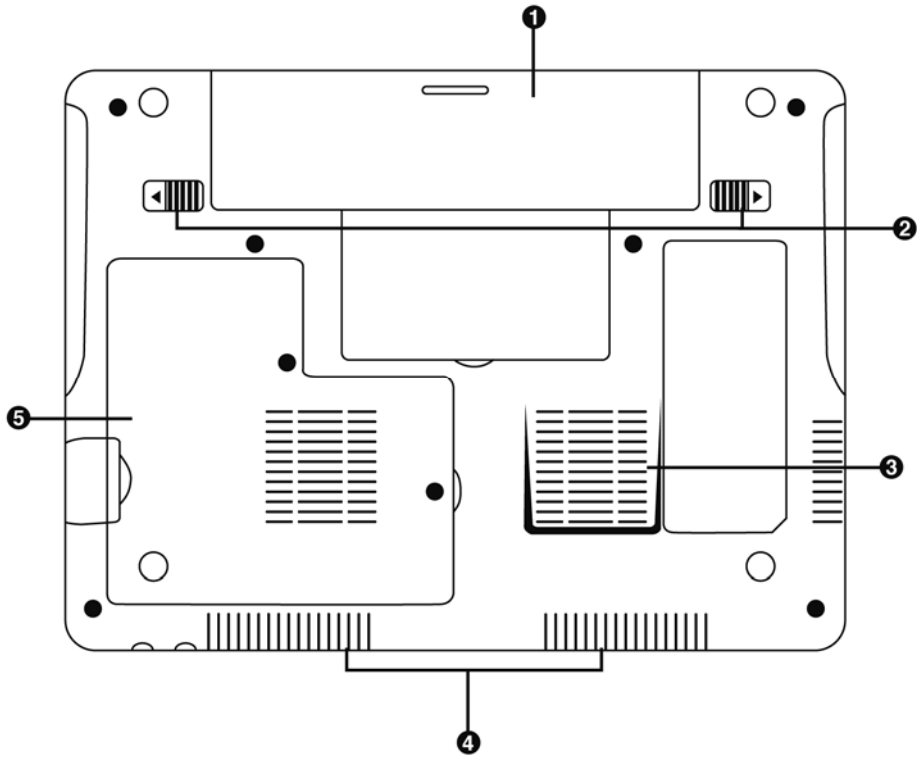

- | | | |
|----------------------------|--------------------|----------------|
| 1. Removable battery | 3. Air intake vent | 5. DDR RAM bay |
| 2. Battery locking latches | 4. Speakers | |



This part of your eCAFÉ™ is liable to heat during operation and charging. This is normal. However, to improve thermal dissipation, we recommend you do not block the vents. Avoid placing your eCAFÉ™ on a soft surface such as a sofa or a bed, for instance.

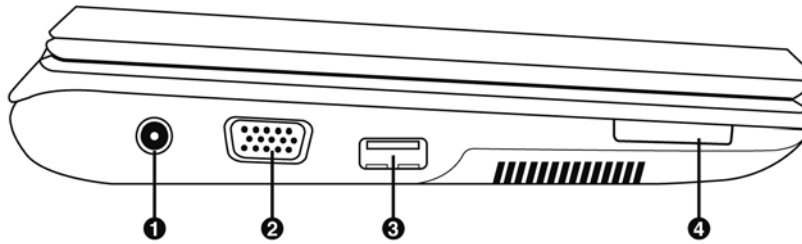

- | | |
|----------------------|----------------------|
| 1. Power cord socket | 3. USB 2.0 port |
| 2. VGA outlet | 4. Memory card drive |

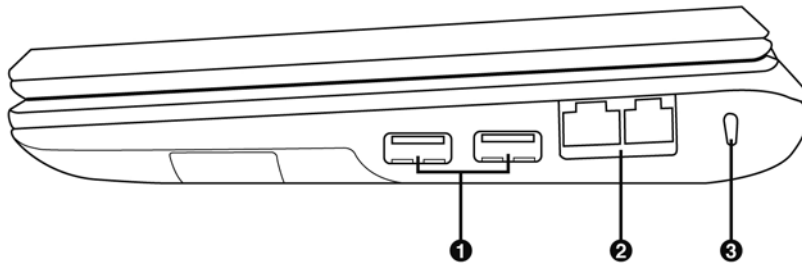

- | | | |
|------------------|-----------------------|---------------------|
| 1. USB 2.0 ports | 2. LAN/Ethernet ports | 3. Kensington® lock |
|------------------|-----------------------|---------------------|

2.2 Multifunction keyboard

eCAFÉ™ features a complete keyboard that lets you control the screen and WiFi connection settings.



Activate/Deactivate WiFi feature (default is inactive)

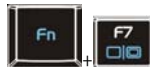

Switch from the LCD display to an external display (For more information regarding the screen resolution, please refer to the Personalisation Wizard, section 3.7.2. Extensive contents to take you further)



Activate/Deactivate audio output



Reduce volume

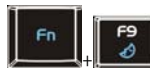

Put computer in standby mode



Increase volume

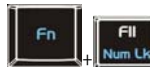

Lock/Unlock the numeric keypad



Reduce display brightness

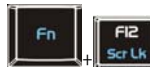

Lock/Unlock the scroll lock function



Increase display brightness



Switch between full screen display and window display modes in the Internet browser

2.3 A netbook suited to large files

Equipped with a hard disk drive and a multiple-format card reader, the eCAFÉ™ enables you to take your most precious files with you, regardless of their size.

Hard disk drive

The eCAFÉ™ features a 60 Go (or more, according to versions) hard disk drive, user space is approximately 50GB. This storage capacity allows you to save movies, images and other large files to your device.

Memory card drive

The eCAFÉ™ is equipped with a multiple-format memory card reader supporting SD and SD HC (Secure Digital), MS (Memory Stick®), MMC (MultiMedia Card) formats; this device enables you to view pictures taken with your digital camera or to extend your system's storage capacity, for instance.

USB ports

The eCAFÉ™ is also equipped with three USB ports that enable you to connect a USB storage key or other USB devices (for further information regarding USB ports, please refer to section 2.4, "Extensive connectivity options for countless applications").

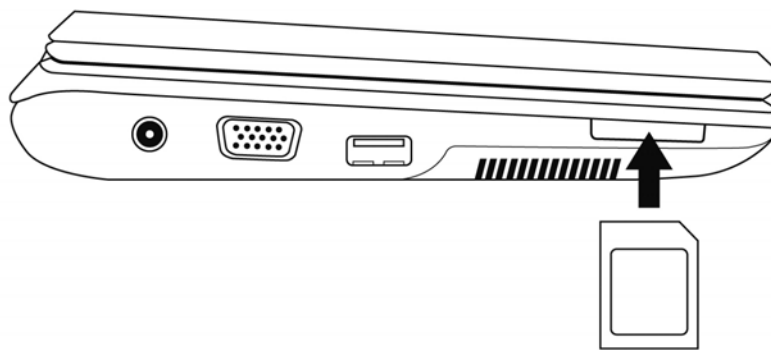

2.4 Extensive connectivity options for countless applications

The ports and connectivity interfaces built into your eCAFÉ™ enable you to connect all kind of USB peripherals, such as a mouse or an external hard disk drive, to your netbook.

General safety rules

Before connecting a peripheral to your netbook, please refer to the installation instructions provided with the device.



Never remove a peripheral while your eCAFÉ™ is reading or saving data; you would risk destroying the data beyond repair.

USB ports (Universal Serial Bus)

The eCAFÉ™ features three USB 2.0 ports (USB 1.1 compatible), to which you can connect many peripherals such as a keyboard, a mouse, a USB key and more. This interface is hot-swappable, allowing you to connect and remove your peripheral without having to first shut it down.

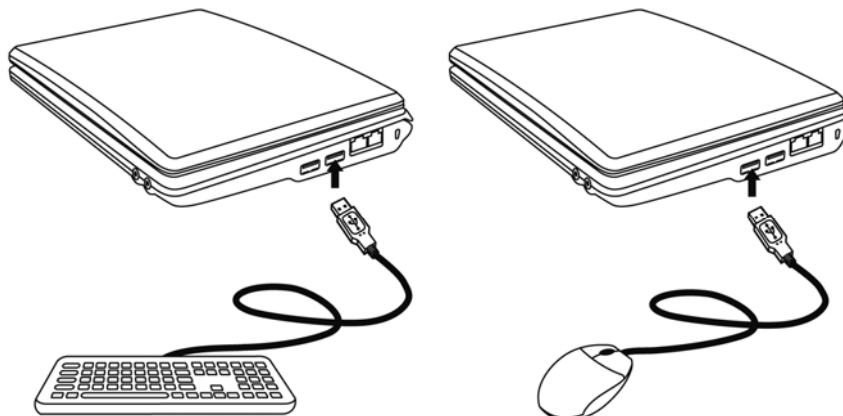



If you have connected a USB external hard disk drive to your eCAFÉ™, please click on the  icon (located in the lower right section of the screen) and select "Remove media" prior to disconnecting your peripheral.



The system may fail to recognise some USB peripherals if they have been connected during the computer's start-up phase. Should this be the case, please remove the device from your netbook and connect it again.

Audio connectors

To initiate a communication or view a video, please connect a microphone, headphones and/or a headset featuring a built-in microphone to the relevant connector:

- The jack output connector to connect headphones or a headset
- The jack input connector to connect an MP3 player for recording purposes, or a microphone to record vocal data or chat with your contacts using a voice-over-IP application

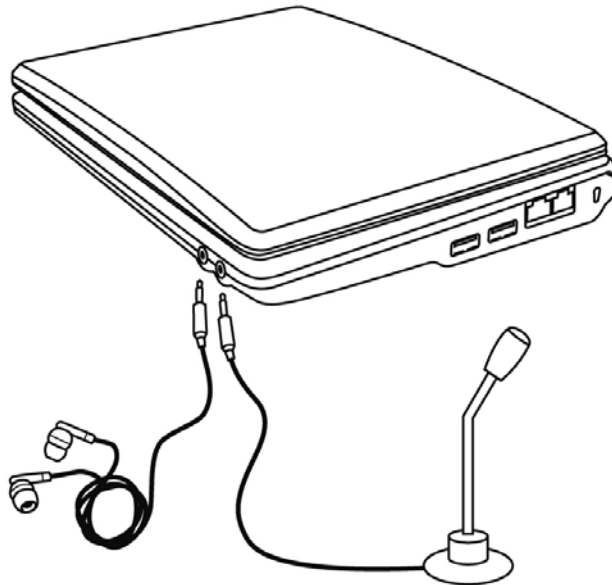

Local Area Network (LAN)

The eCAFÉ™ is equipped with a RJ45 LAN connectivity interface, which enables you to connect it to a 10/100 Mbps wired network (corporate network, router, wired modem & router or Internet box, for instance).

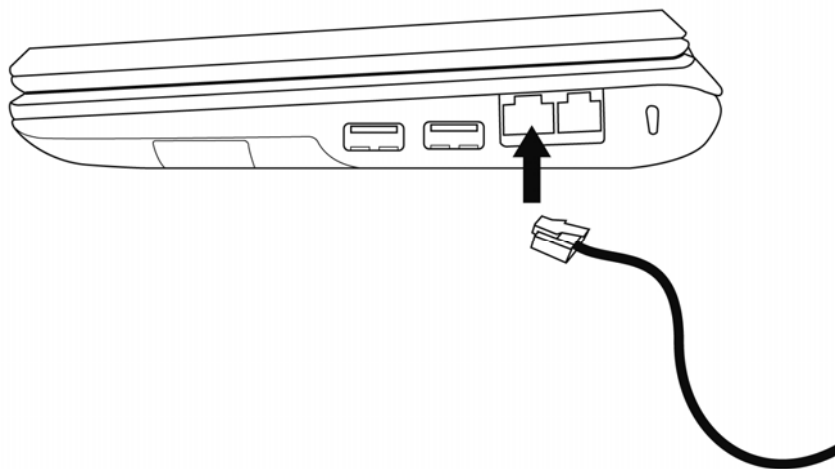

2.5 A desktop device AND a mobile device

Both a desktop device and a mobile device at once, the eCAFÉ™ can be used everywhere thanks to its dual power supply (mains or battery).

2.5.1 Operating the eCAFÉ™ when connected to the mains

Use the included power adaptor to power your eCAFÉ™. The device complies with the specifications of the electric network in the country in which the device was purchased.



Please make sure that the power supply plug is fully engaged into the computer's power supply connector.

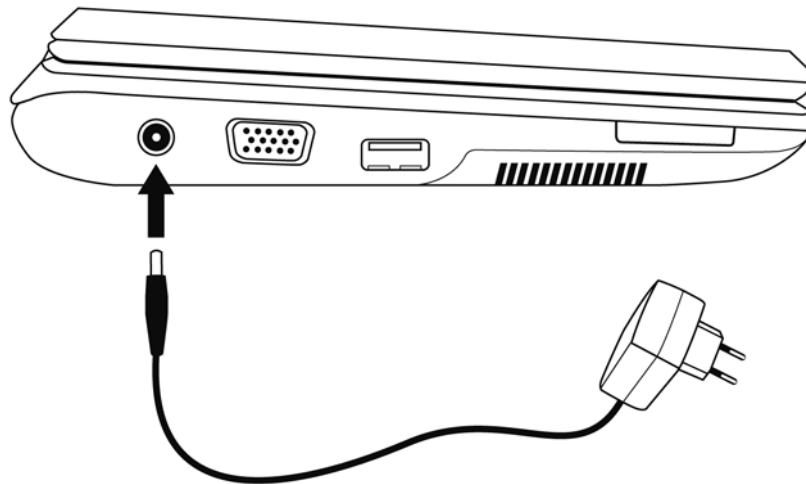

When the eCAFÉ™ is connected to the mains, the device's battery starts to charge automatically. Please note that fully charging the eCAFÉ™ while the device is in use requires more time than when the eCAFÉ™ is turned off.

2.5.2 Operating the eCAFÉ™ with the built-in battery

The eCAFÉ™ is designed to operate on its built-in battery. When fully charged, the built-in battery guarantees ample autonomy (over 5 hours*). You can purchase additional batteries from your sales outlet.



To extend your battery's lifespan, we recommend that you charge it fully when using your eCAFÉ™ for the first time. Please refer to the battery charge status indicator for more information regarding the battery charge level.

* Battery life calculated based on a simulation in which the following activities were carried out in succession: word processing, Internet browsing, standby mode approximately 5 minutes per hour of use. Battery life duration may vary and depends on how eCAFÉ™ is used (types of use, network conditions).

2.5.3 Installing and removing the battery

You may need to install or remove the battery, e.g. when replacing the battery.

 Before installing or removing the battery, place the **locks (2)** in the "Unlocked" position; install or remove the battery, then place the locks in the "Locked" position again.

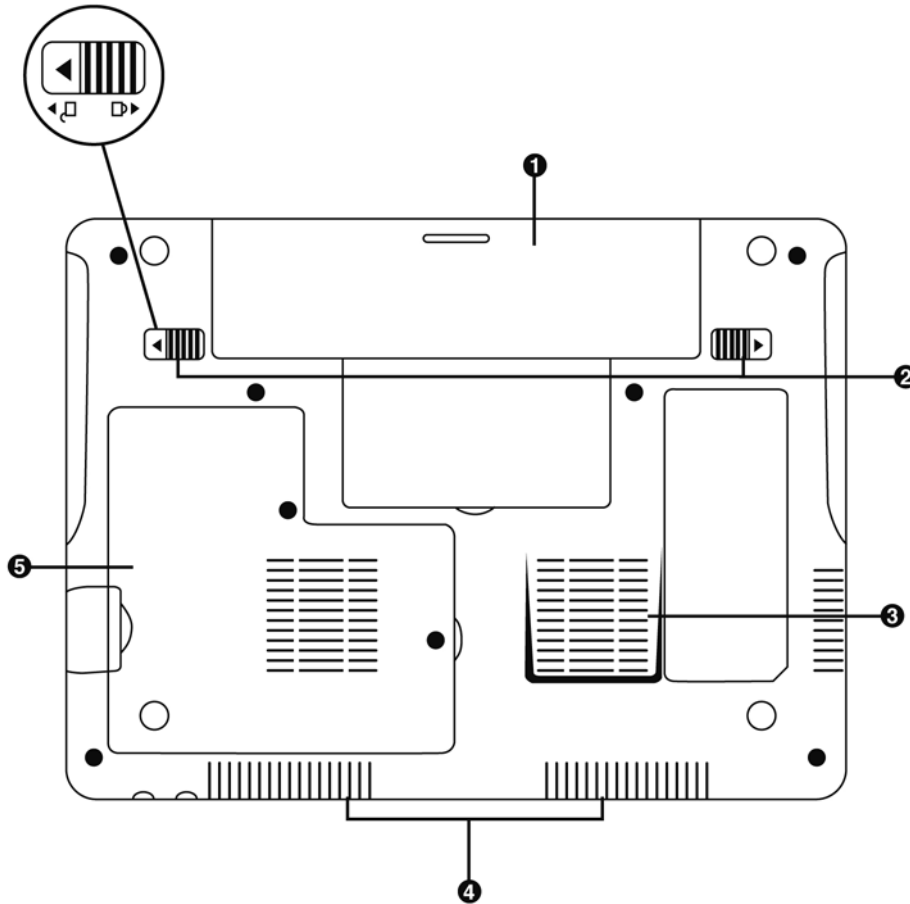

 Always shut your eCAFÉ™ down before installing or removing the battery!

 Use only **Hercules** batteries that are fully identical to the original batteries included with your eCAFÉ™. Failure to comply with these instructions may cause damage to your eCAFÉ™. Similarly, there is a risk of explosion if the battery is replaced by an inappropriate battery. Please comply with the regulations on proper battery disposal.

Installing the battery

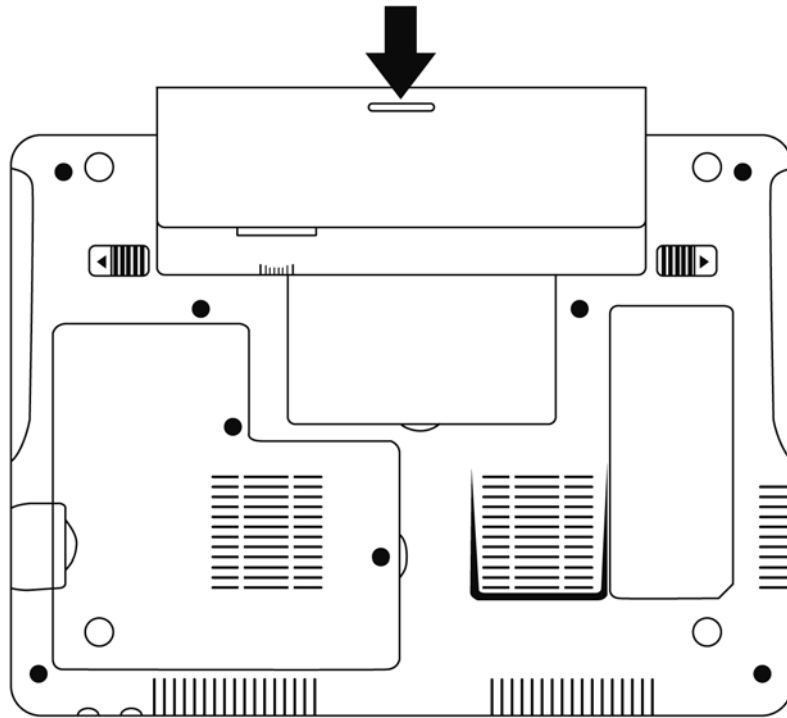

Removing the battery

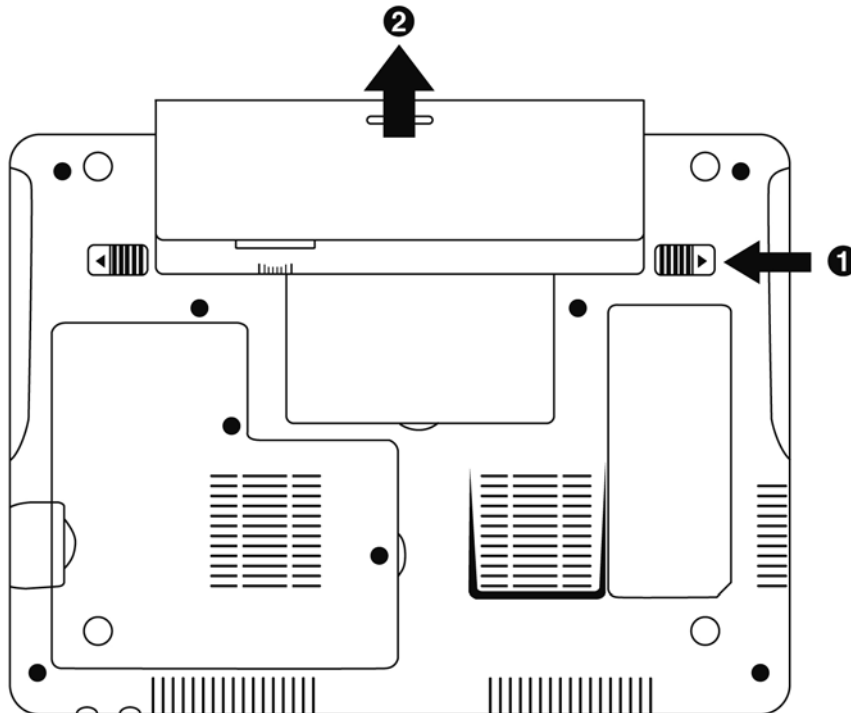

2.5.4 Optimising your use of the battery

This netbook battery pack uses lithium ion (Li-Ion) battery cells and can be charged at any time. If you will not be using the netbook for 30 days, please remove the battery pack from the netbook. The battery should be at over 70% of its capacity before you remove it. The recommended storage temperature of a Li-based battery is 5°C~35°C. It should not be stored in a hot car. The Li-Ion battery pack deteriorates whether or not it is used. Typical life is 2~3 years.

To extend your netbook battery's lifespan:

- Adjust the display's luminosity to a level suited to your environment (indoors/outdoors) and to the application that you are using.



Reduce display
brightness



Increase display
brightness

- Close the display when you are not using your eCAFÉ™ for a short time. The display will automatically turn off.
- When using your eCAFÉ™ for the first time, always charge the battery entirely.
- Deactivate the WiFi function if you are not using WiFi networks.

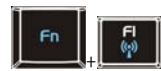

Deactivate WiFi

3. FIRST STEPS WITH MY eCAFÉ™

3.1 Turning the eCAFÉ™ On/Off

Turning the device on

- Open the display (1) and press the On/Off button located on the right-hand side of the device (2).

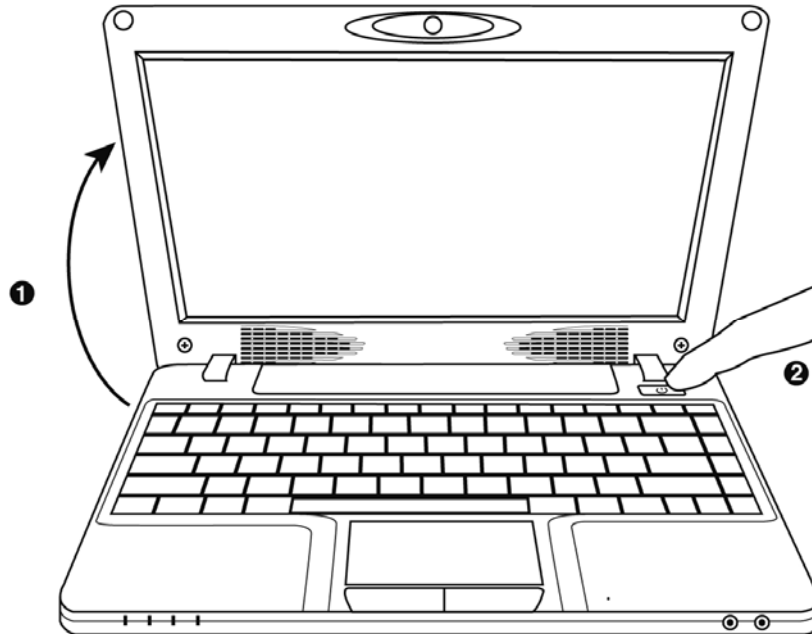

Do not exert excessive strength on the hinges when opening the display. Do not hold your eCAFÉ™ by the display when carrying the device.



When your computer starts up, the Home world is displayed; this page is the starting point of your journey throughout the eCAFÉ™ galaxy. You will have the opportunity to discover many other worlds, each world being dedicated to a specific use: **Work**, **Communications**, **Games**, viewing **Multimedia** contents and configuring or modifying your netbook's **Settings**.



Shutting the device down

- Before shutting your eCAFÉ™ down, make sure that all your programs and applications have shut down tidily.

- Shut your eCAFÉ™ down by clicking on the  icon in the lower left-hand section of the screen, then select **Shut computer down**.

Forcing the computer to shut down or restart

If you have trouble starting your computer up, press the device's On/Off button and hold it down until your eCAFÉ™ shuts down.

If an unexpected configuration prevents your eCAFÉ™ from reverting to its initial state when you press the  key, press keys  +  simultaneously. The system will then proceed to restart the various worlds; this quick restart lasts only a few seconds.



Do not use the forced shutdown or restart procedures when files are open. Irreparable loss of data may occur in this case.

3.2 Connecting an external display

When you are at home or working at the office, you can connect your netbook to a larger screen, e.g. to surf the Internet or work on large spreadsheets. To do so, simply connect your eCAFÉ™ to a VGA screen using the device's VGA connector. For more information regarding display settings, please refer to the Personalisation Wizard in section 3.7.2., "Extensive contents to take you further").

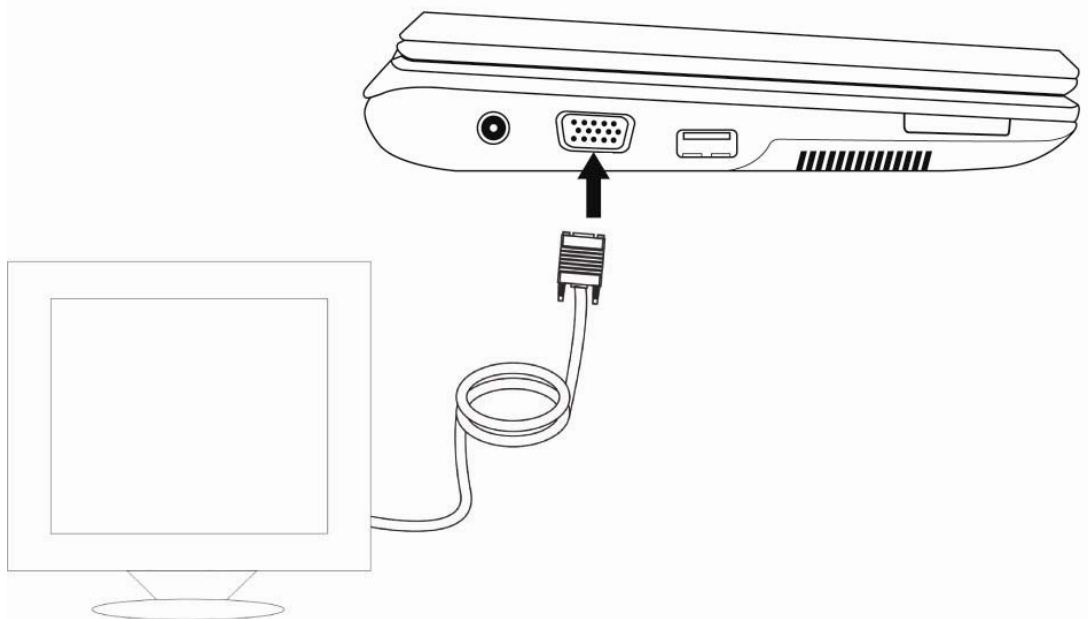

3.3 Connecting a keyboard and a mouse

You can also connect a keyboard and/or a mouse to the device's USB ports.

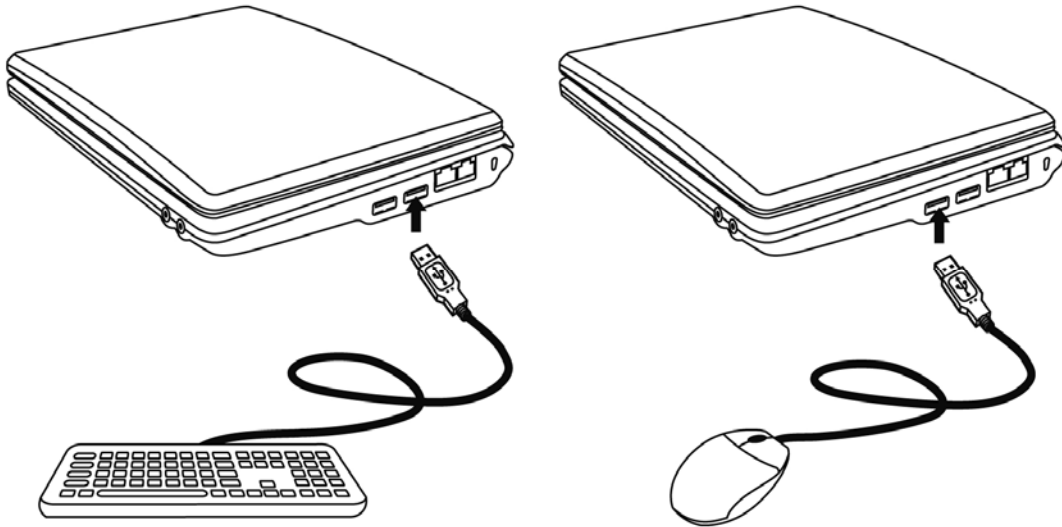

3.4 Connecting headphones and a microphone

To fully enjoy your music and movies or to chat with friends, you can connect headphones or a speaker kit to your netbook (3.5-inch jack connector).

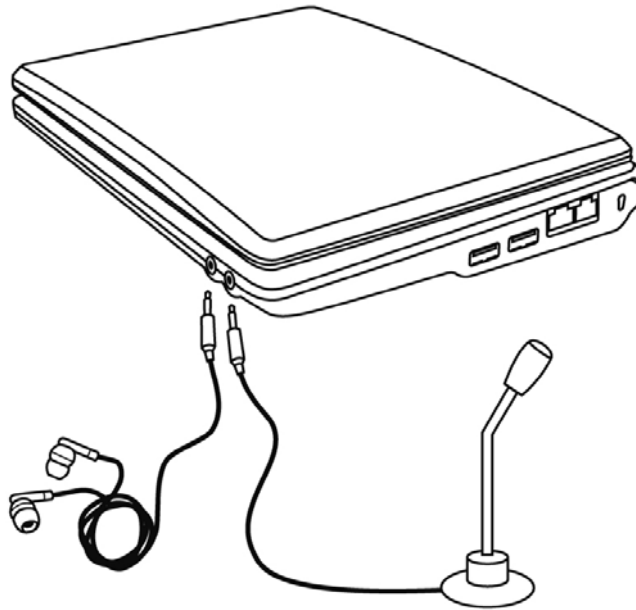

Connecting an audio peripheral automatically deactivates the microphone or speakers eCAFÉ™'s built-in speakers.

3.5 Mastering the touchpad

Some actions are confirmed by a single click (activating a button or accessing a menu, for instance):

Either by pressing the left touchpad button once

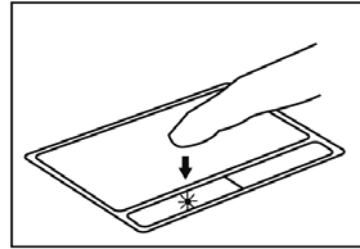

Either by briefly tapping the touchpad

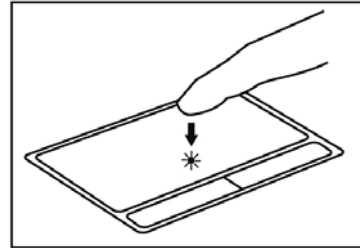

Other actions are confirmed by means of a double-click (opening audio or video contents or a document, for instance):

Either by pressing the left touchpad button twice

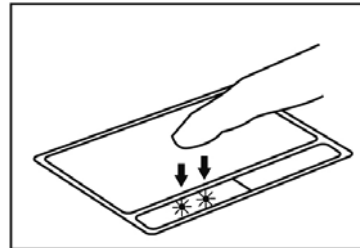

Either by briefly tapping the touchpad twice

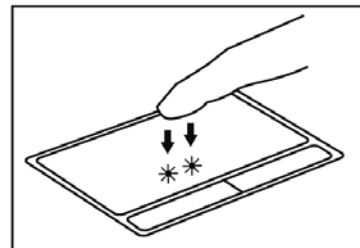

The **right touchpad button** is generally used to access the selected object's properties.

3.6 Accessing the help interface

This guide is available in the "User's Manual" PDF file located on your eCAFÉ™'s hard disk drive (in the folder named "MyFiles", which contains your personal files).

Specific help is also available within each installed application. Please refer to the relevant help section if necessary.

3.7 Welcome to the eCAFÉ™ galaxy!



3.7.1 All the essentials in just one click

When your computer starts up, the Home world is displayed: this page is the starting point of your journey throughout the eCAFÉ™ galaxy. You will have the opportunity to discover many other worlds, each world being dedicated to a specific use: **Work**, **Communications**, **Games**, viewing **Multimedia** contents and configuring or modifying your netbook's **Settings**.













The icon opens the eCAFÉ™ portal, which allows you to access your online world, view detailed information about the eCAFÉ™ solutions range, discover new applications, obtain hints and tricks, learn whether your netbook is compatible with your equipment or simply discover new uses for your system.

On the left-hand side of the screen, an icon bar enables users to quickly access the various applications and worlds.

All applications can be accessed by clicking on the  icon.

You can access the eCAFÉ™'s graphic preferences by clicking on the  icon.

- | | | | |
|---|--|---|---------------------------------|
|  | Switch to the Home world key |  | Access the Home world |
|  | Access all applications directly |  | Access the Communications world |
|  | Access the Personalisation Wizard to customise your netbook's settings |  | Access the Games world |
|  | Open the File Browser |  | Access the Multimedia world |
|  | Open the eCAFÉ™ portal |  | Access the Work world |
| | |  | Access the Settings world |

- The Home world



- The Communications world



- The Games world



- The Multimedia world



- The Work world



- The Settings world



3.7.2 Extensive contents to take you further

Users wishing to explore all the eCAFÉ™'s possibilities will enjoy the wide range of office and communication tools and games; the eCAFÉ™'s world can even be customised using user-friendly and intuitive tools.

The Personalisation Wizard



Launch the Personalisation Wizard



Click on the icon in the upper left section of the screen to open the Personalisation Wizard, which enables you to:

- Adjust screen resolution and select an output display on the **Screens and resolutions** thumbnail
- Add quick access links to your favourite applications on the **Desktop** thumbnail
- Customise the Home world by changing the background image on the **Background** thumbnail
- Configure your screensaver on the **Standby** thumbnail



To customise your Home world using a **background image** (without deformation or unwanted pixels), we recommend you select an image with a resolution of 1024x600 pixels.

Direct access to all applications



Access all applications directly

This menu is accessible from the application quick launch bar. It enables you to access all installed applications via an interface featuring an array of menus and submenus.

The File Browser



Open the File Browser

The File Browser enables you to access all the **files** stored on your eCAFÉ™ and to create new files. Several file types are available: text files, image files, audio files and video files, among others.

These files can be stored in separate **directories** on your eCAFÉ™'s hard disk drive or on an external memory unit (e.g. an external hard disk drive, a USB key or a memory card). A folder can contain various types of files. For instance, if you create a "Birthday" directory, this folder can contain pictures taken at the birthday party, as well as a video or the invitation card text.

Files can be created directly from the applications available on the eCAFÉ™; they can also be loaded from external peripherals.

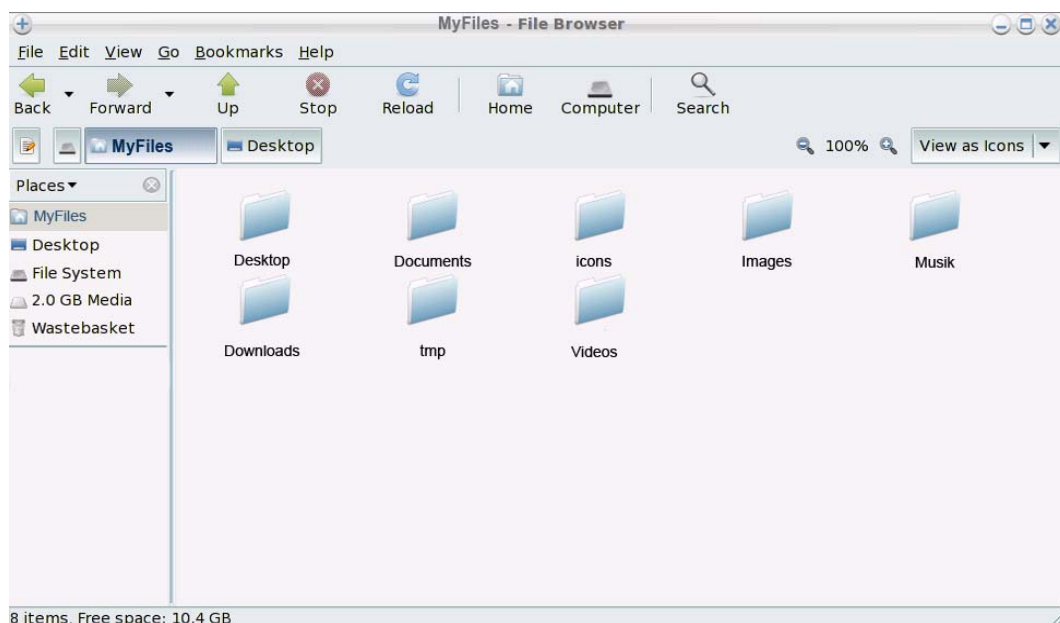

Load my files from a USB key:

- Connect your USB key to one of the two available USB ports. The eCAFÉ™ automatically detects the newly connected device and displays the USB symbol in the status bar.
- In the File Browser that automatically appears onscreen, click on your USB key's name (it is now displayed in the left-hand pane).
- Select the files that you wish to load (hold the  key to select several consecutive files, or hold the Ctrl key to select several non-consecutive files).
- In the Edit menu, select Copy.
- In the File Browser, select a destination location for your files.
- In the Edit menu, select Paste.

Load my files from a memory card:

- Insert the memory card in the memory card reader. The eCAFÉ™ automatically detects the newly connected device.
- In the File Browser, click on your memory card's name (which now appears in the left-hand pane).
- Select the files that you wish to load (hold the  key to select several consecutive files, or hold the Ctrl key to select several non-consecutive files).
- In the Edit menu, select Copy.
- In the File Browser, select a destination location for your files.
- In the Edit menu, select Paste.

Load my files via a network connection:

To load files via a network connection, you must connect your eCAFÉ™ to a network using the Ethernet port or a WiFi connection. You can then access the relevant files via the network.

Load my photos from a digital camera

- Connect a digital camera to one of the two available USB ports.
- Turn your digital camera on. The eCAFÉ™ automatically detects the newly connected device. The **Import images from a digital camera** menu is displayed.
- Select **Import photos**. The Photo Manager software launches automatically.
- Select **Copy**. All the images stored in the digital camera are selected. They are then copied from the digital camera to your eCAFÉ™'s hard disk drive (in the Images directory). The message "File copy complete" is displayed onscreen.
- Select OK.

Status bar and Notification area

The status bar displays the thumbnails of the currently launched applications, while the notification area (located in the lower right-hand section of the screen) displays the battery's charge level and status, the network connection (WiFi or Ethernet), the status of the Caps lock and Keypad lock keys, the CPU usage level and a clock.



3.8 Adjusting the main settings

3.8.1 eCAFÉ™ Connect and the WiFi feature



Launch eCAFÉ™ Connect from the Communications world
Option no. 1



Launch eCAFÉ™ Connect from the status bar
Option no. 2



Activate/Deactivate the WiFi feature

eCAFÉ™ Connect is a software application developed by Hercules, which enables you to manage your network connections (both Ethernet and WiFi) in a user-friendly, intuitive way. It is the essential complement of the eCAFÉ™'s built-in WiFi card

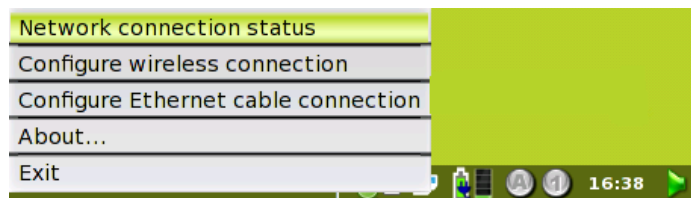

To access eCAFÉ™ Connect (option no. 2):

- Right-click on the Hercules eCAFÉ™ Connect icon located in the status bar using the right touchpad button.



- Select **Network connection status**.

- Activate your eCAFÉ™'s WiFi feature by pressing on keys  and . The computer's WiFi  indicator should light up.

 This feature is not activated when the system starts up, and the WiFi indicator  is off.



- Click on the **Connect** button facing the wireless connection.

You will now access the WiFi connection manager named eCAFÉ™ Connect WiFi Station. For more information regarding the WiFi connection manager, and for more information on how to connect to a WiFi network and store your favourite networks on your computer, please refer to section 4.1.1., "Connecting to the Internet... using the WiFi feature".

3.8.2 Date and time

To adjust the date and time, click on the clock located in the status bar, in the lower right-hand section of the screen.

Click on the clock



The settings pane displays:

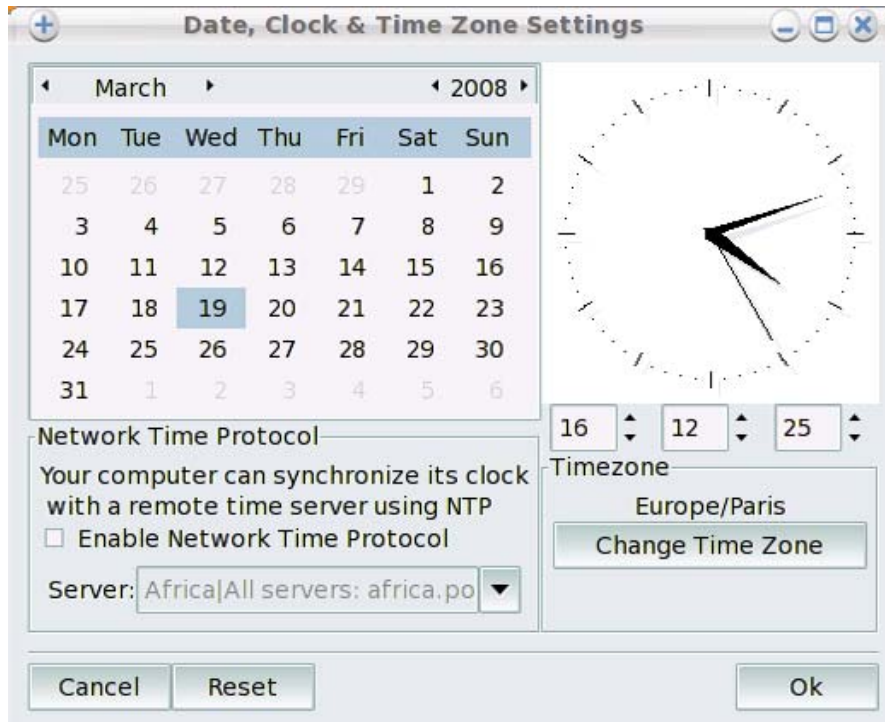

3.8.3 Language

To select the interface language, access the **Settings** world, and then click on **Computer Configuration**.

The **Control Centre** displays. Select the **System** thumbnail, and then click on the **Manage your system's local settings** icon.

Select a language in the displayed list. Click on **Next**, then **Next** again, and then click on **OK** to confirm your choice.

3.8.4 Volume

Click on the volume icon located in the status bar.

Click on the volume icon



You can also click on the applications quick access icon . Select **Settings**, then **Volume control**.

The settings pane displays.

3.8.5 Printers

Access the **Settings** world, then click on **Computer Configuration**.

The **Control Centre** displays. Select the **System** thumbnail, then click on the **Configure printer(s)** icon. Follow the instructions displayed onscreen.

3.9 Customising your world

3.9.1 Defining user profiles

Access the **Settings** world, then click on **Computer Configuration**.

The **Control Centre** displays. Select the **Security** thumbnail, then click on the **Manage the system's users** icon.

3.9.2 Customising the interface's appearance



Launch the Personalisation Wizard.

The Personalisation Wizard enables you to easily add quick access links to your favourite applications, or to customise the appearance of the

Home world by changing the background image. This application is accessible via the



icon located in the upper left-hand section of the screen.

To **add quick access links**, access the **Desktop** thumbnail and select your world (upper left-hand section of the screen). This list of applications currently featured in this world displays onscreen. To add an application, select the chosen application in the right-hand list and drag it towards the world.

To **change the background image**:

- Access the **Desktop** thumbnail.
- Select the **Home** world.
- Click on the image that appears at the bottom of the window, then click on the **Browse** button.
- Select the location of your image file (the recommended image size for optimum display quality is 1024x600 pixels).
- Click on **OK** to apply the new background image.

4. COMMUNICATIONS

Access the Communications world.

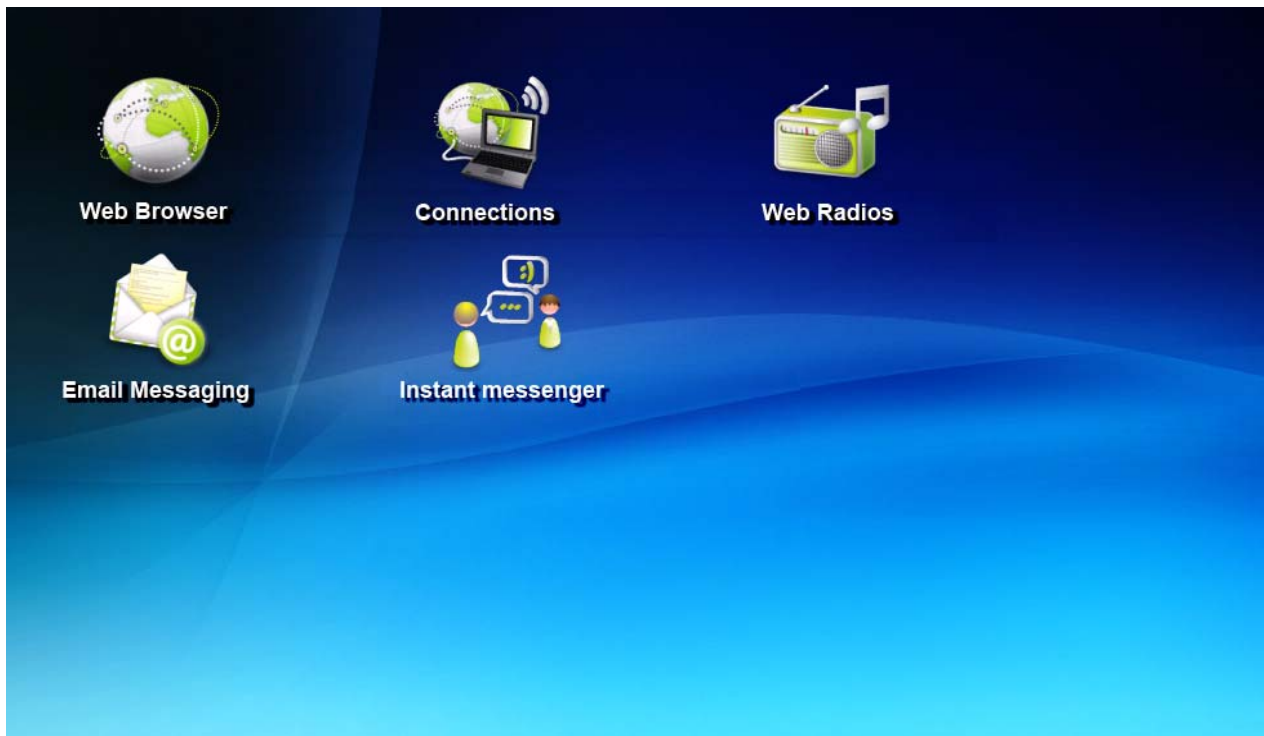

4.1 Connecting to the Internet

4.1.1 ...using the WiFi feature

Connect to the Internet with unrivalled ease – and without cables – thanks to eCAFÉ™ Connect, the software application developed by Hercules, which enables you to manage your WiFi network connections in a user-friendly, intuitive way.

In this section, we will take a closer look at how to connect to the Internet using your netbook's WiFi feature – a feature that is hugely appreciated by mobile users who need to connect to the Internet or check their email account at all times.

- Access the **Communications** world and click on **Connections**, or click on the Hercules eCAFÉ™ Connect icon located in the status bar.

The eCAFÉ™ Connect window opens.

- Activate your eCAFÉ™'s WiFi feature by pressing on keys  and . The computer's WiFi indicator  should light up.



We shall now proceed to locate the available WiFi networks and proceed to set up a wireless connection to the Internet.

- Click on the **Configuration** button facing the wireless connection.

The eCAFÉ™ Connect WiFi Station application proceeds to automatically locate the available networks, and displays the detected networks.

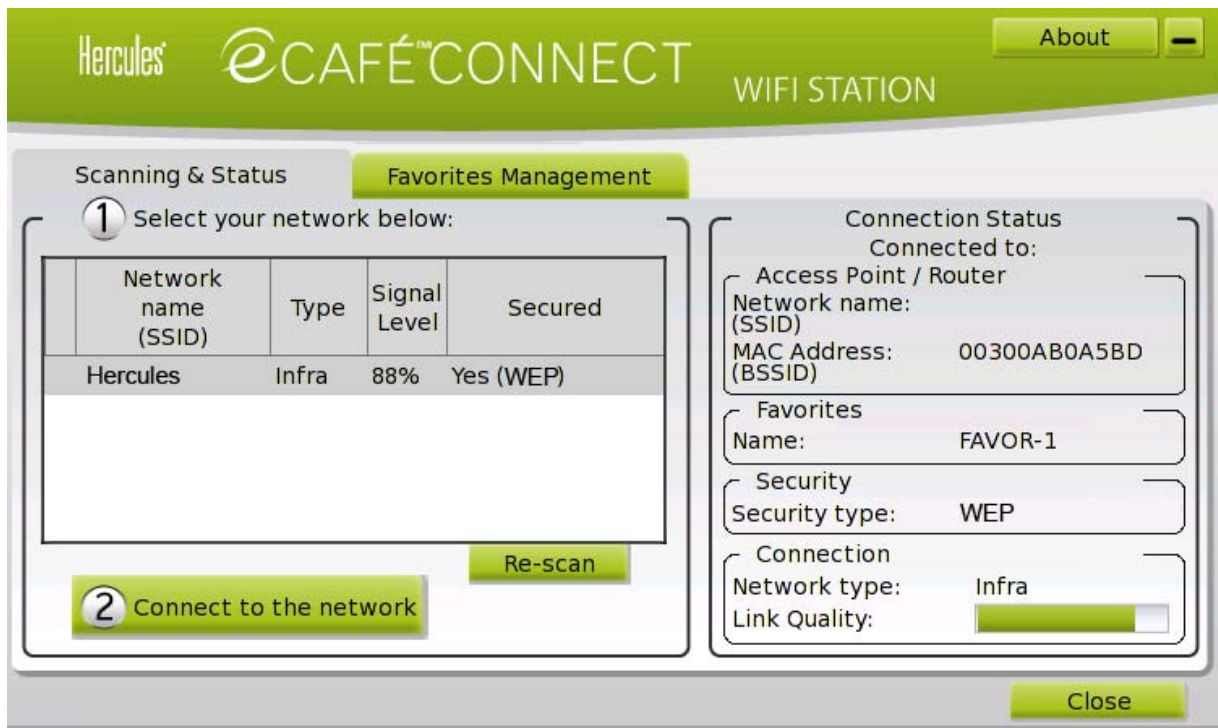

Connecting to a non-secure network (no key type appears in the Secure field):

- Select the relevant network.

- Click on the **Connect to the network** button.

A Connection Wizard launches, and asks you if you wish to add this network to your favourites.

- If you wish to do so, you can add the network to your favourites by checking the Yes box; you will then be requested to provide a name for the network.

A few seconds later, a green icon displays facing the network, indicating that you are successfully connected.

If you want your computer to automatically connect to a specific network when the WiFi feature is activated, add the network to your Favourites list and select the **Connect automatically** option.



If the connection to the chosen network fails in the **Infrastructure mode**, check your router's security settings (key, MAC address filtering etc.).

Note: The **Infrastructure mode** is a communication mode that consists in creating a network connecting several computers equipped with a WiFi feature via a wireless access point such as an Internet box, a modem/router or a router connected to a modem. The **Infrastructure mode** is ideal for exchanging data or playing games over a network, but also for sharing an Internet connection and/or a printer between several computers.

The **Ad hoc mode** is a mode that enables several computers equipped with a WiFi feature to communicate directly with each other. This mode is also called "Peer to Peer".

A **MAC address** is a unique address created by the router's vendor; it serves to identify this device on a network. The MAC address is comprised of the organisation's (i.e. the vendor's) identifier, followed by the device's unique identifier.

To connect to a secure network (a key type appears in the Secure field):

- Select the relevant network.
- Click on **Connect to the network**.
- Enter the security key when asked by the WiFi Station application.
- If you wish to do so, you can add the network to your favourites by checking the **Yes** box; you will then be requested to provide a name for the network.



If you wish to connect to a secure network, you must have access to the network's security key. Before the connection can be made, the eCAFÉ™ Connect WiFi Station application will ask you to provide this key (a message will help you identify the required type of key).

To connect to a hidden network (the Network name (SSID) field is empty):

If, among the located networks, one or more networks do not have a name (i.e. the Network name (SSID) field is empty), this means that the network is not broadcasting its name. To connect to this network, select it, then:





- Click on the **Connect to the network** button.
- Enter the network's name (SSID) in the window that displays.
- If this network is secure, enter the used security key.
- If you wish to do so, you can add the network to your favourites by checking the **Yes** box; you will then be requested to provide a name for the network.



For greater browsing comfort, you can either use your Internet browser's zoom function  or press the F11 key to switch between full screen mode and window display mode.

For more information about the connection's status:

The eCAFÉ™ Connect icon appears in the notification area. It provides updated information about the connection's status:

	Internet connection: an Ethernet or WiFi peripheral is active and physically connected; Internet access is available.	Your Internet connection is perfectly operational.
	Local connection: an Ethernet or WiFi peripheral is active and physically connected; no Internet access is available.	You are connected to a modem, a router or an Internet box or to a corporate network; however, this device or network is not connected to the Internet. Please check the Internet connection settings on your local area network or your modem.
	Connection problem: an Ethernet or WiFi peripheral is active and physically connected; no Internet access is available.	Please check your network connection settings (IP address, subnet mask etc.) on your local area network or your modem. If necessary, contact your router's or modem/router's vendor.
	No connection: an Ethernet or WiFi device is active but is not connected physically.	Connect your eCAFÉ™ to a local area network via the WiFi connection (please refer to the previous section) or via the Ethernet port.
	No peripheral: no Ethernet and/or WiFi peripheral has been activated.	Activate your peripheral: to activate your WiFi peripheral, simultaneously press on keys [Fn] and [F1] on your netbook's keyboard.

4.1.2 ...via a DSL connection or a local area network

To connect to the Internet via a DSL connection or a local area network, simply connect your eCAFÉ™ to the DSL modem or local area network's Ethernet port.

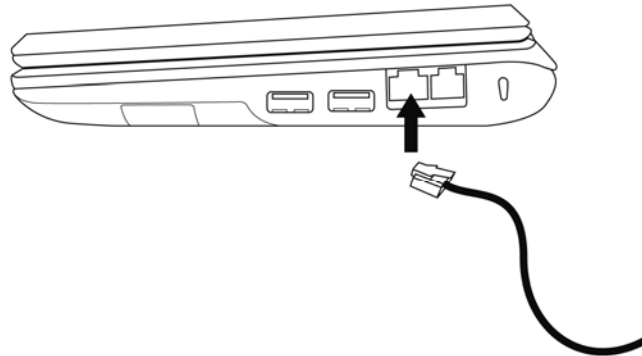





An information window displays in your eCAFÉ™'s status bar, enabling you to view the network connection. Then, launch your Internet browser.



For greater browsing comfort, you can either use your Internet browser's zoom function  or press the F11 key to switch between full screen mode and window display mode.

For more information about the connection's status:

The eCAFÉ™ Connect icon appears in the notification area. It provides updated information about the connection's status:

	Internet connection: an Ethernet or WiFi peripheral is active and physically connected; Internet access is available.	Your Internet connection is perfectly operational.
	Local connection: an Ethernet or WiFi peripheral is active and physically connected; no Internet access is available.	You are connected to a modem, a router or an Internet box or to a corporate network; however, this device or network is not connected to the Internet. Please check the Internet connection settings on your local area network or your modem.
	Connection problem: an Ethernet or WiFi peripheral is active and physically connected; no Internet access is available.	Please check your network connection settings (IP address, subnet mask etc.) on your local area network or your modem. If necessary, contact your router's or modem/router's vendor.
	No connection: an Ethernet or WiFi device is active but is not connected physically.	Connect your eCAFÉ™ to a local area network via the WiFi connection (please refer to the previous section) or via the Ethernet port.
	No peripheral: no Ethernet and/or WiFi peripheral has been activated.	Activate your peripheral: to activate your WiFi peripheral, simultaneously press on keys [Fn] and [F1] on your netbook's keyboard.

4.2 Sending and receiving emails

Whether at home or "on the road", it is often useful to be able to access your email account. Once connected to the Internet, you can send and receive emails and attachments using the **Email** application provided with your eCAFÉ™.



Please refer to the connection information provided by your Internet Services Provider. You will need this information to configure your email account correctly.

The Email Configuration Wizard launches when you first run the Email application, in order to help you setup your email account.

1. In the Welcome window, click on Next.

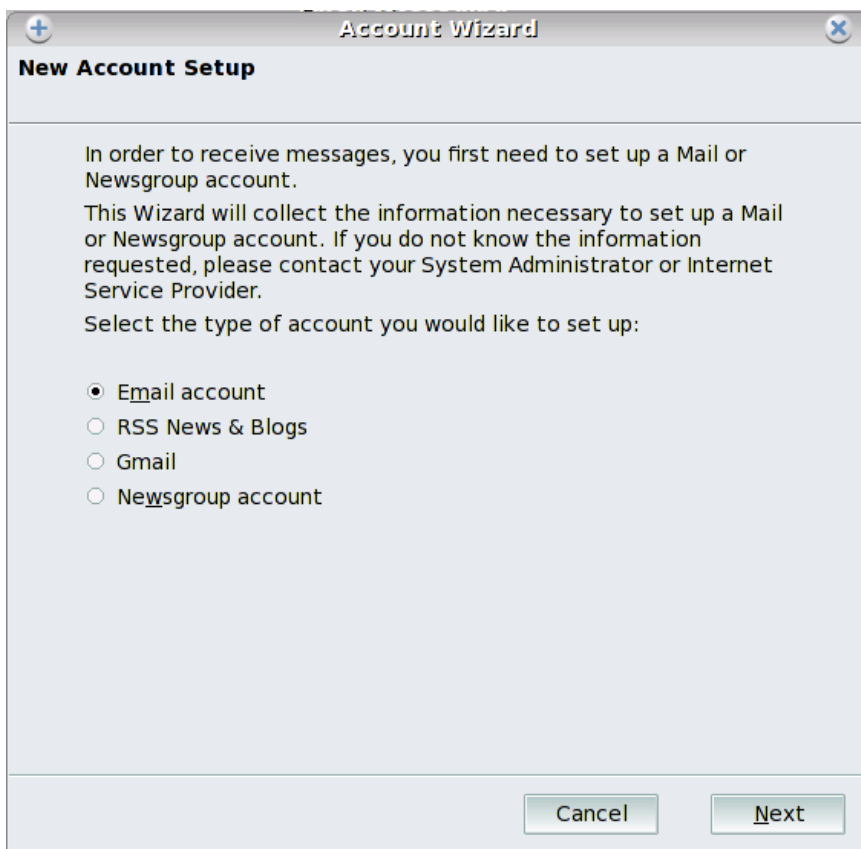

The screenshot shows a dialog box titled "Account Wizard" with a subtitle "New Account Setup". The text inside reads: "In order to receive messages, you first need to set up a Mail or Newsgroup account. This Wizard will collect the information necessary to set up a Mail or Newsgroup account. If you do not know the information requested, please contact your System Administrator or Internet Service Provider. Select the type of account you would like to set up:". Below this text are four radio button options: "Email account" (which is selected), "RSS News & Blogs", "Gmail", and "Newsgroup account". At the bottom right of the dialog are two buttons: "Cancel" and "Next".

2. Enter your name. This information will appear in the emails that you will send. Also enter your email address (please make sure that it is valid). Click on Next.

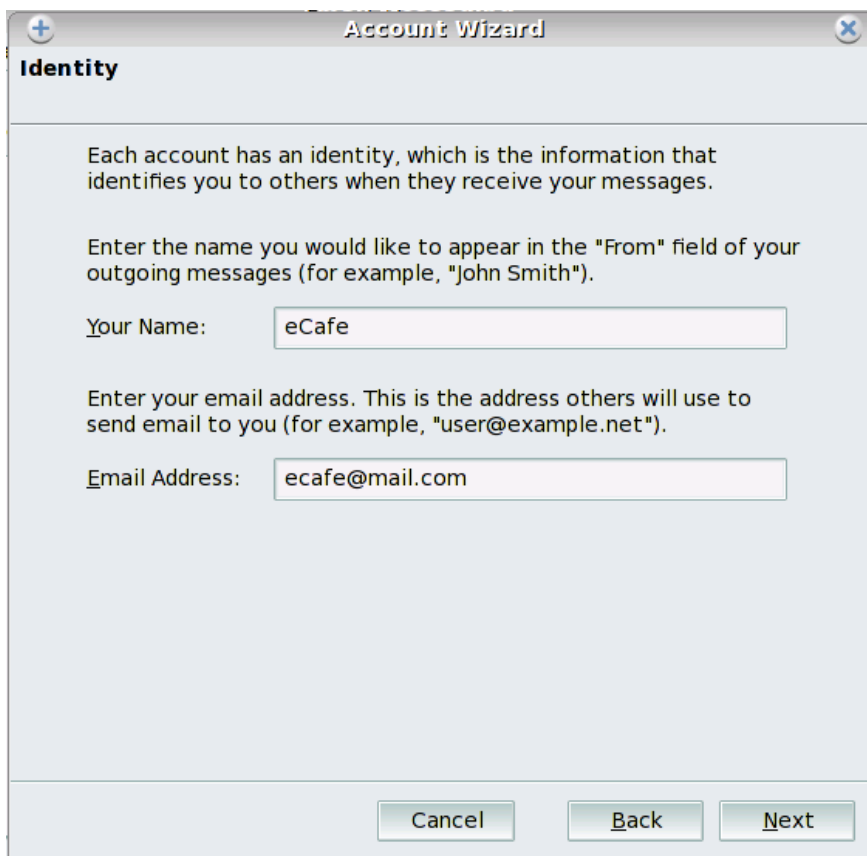

The screenshot shows a dialog box titled "Account Wizard" with a subtitle "Identity". The text inside reads: "Each account has an identity, which is the information that identifies you to others when they receive your messages. Enter the name you would like to appear in the 'From' field of your outgoing messages (for example, 'John Smith')." Below this text is a label "Your Name:" followed by a text input field containing "eCafe". The text continues: "Enter your email address. This is the address others will use to send email to you (for example, 'user@example.net')." Below this text is a label "Email Address:" followed by a text input field containing "ecafe@mail.com". At the bottom of the dialog are three buttons: "Cancel", "Back", and "Next".

3. Select the incoming server type (POP or IMAP). Enter the names of the incoming and outgoing mail servers, which respectively deal with receiving and sending your emails. Click on **Next**.



The screenshot shows the 'Account Wizard' dialog box with the 'Server Information' tab selected. The window title is 'Account Wizard'. The main heading is 'Server Information'. The text reads: 'Select the type of incoming server you are using.' Below this are two radio buttons: 'POP' (selected) and 'IMAP'. The next instruction is: 'Enter the name of your incoming server (for example, "mail.example.net").' Below this is a text input field labeled 'Incoming Server:' containing the text 'mail.com'. The following text is: 'Uncheck this checkbox to store mail for this account in its own directory. That will make this account appear as a top-level account. Otherwise, it will be part of the Local Folders Global Inbox account.' Below this is a checked checkbox labeled 'Use Global Inbox (store mail in Local Folders)'. The next instruction is: 'Enter the name of your outgoing server (SMTP) (for example, "smtp.example.net").' Below this is a text input field labeled 'Outgoing Server:' containing the text 'mail.com'. At the bottom of the dialog are three buttons: 'Cancel', 'Back', and 'Next'.

4. Enter your user name (as it appears on the printed material provided by your ISP). Click on **Next**.

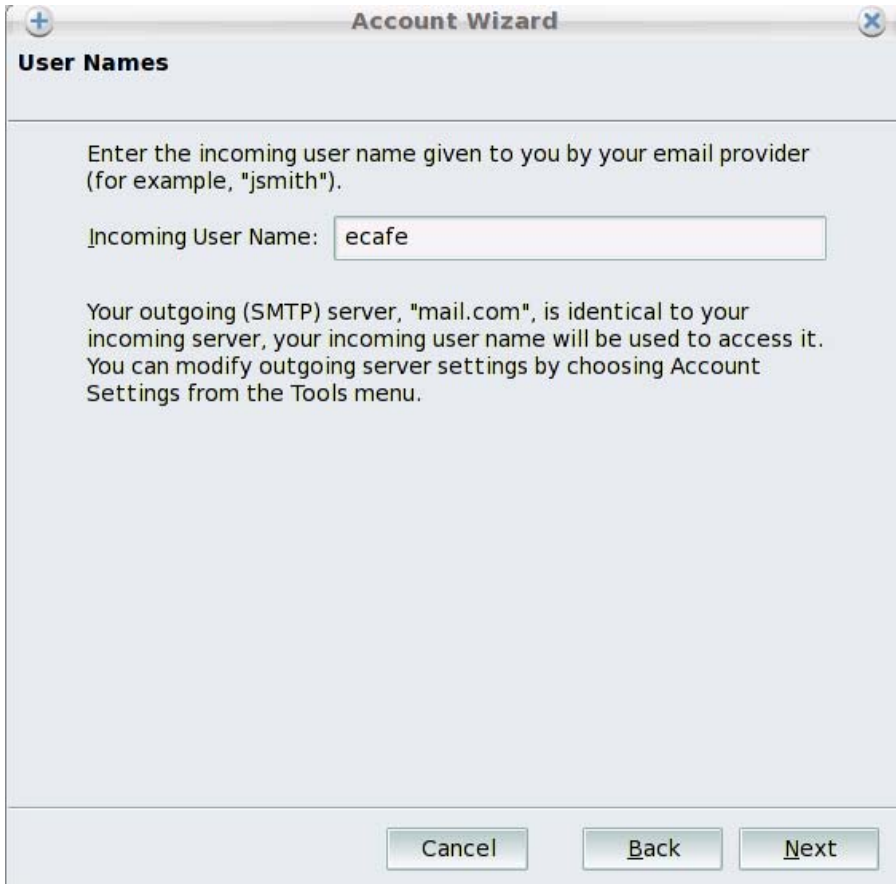

The screenshot shows the 'Account Wizard' dialog box with the 'User Names' tab selected. The window title is 'Account Wizard'. The main heading is 'User Names'. The text reads: 'Enter the incoming user name given to you by your email provider (for example, "jsmith").' Below this is a text input field labeled 'Incoming User Name:' containing the text 'ecafe'. The following text is: 'Your outgoing (SMTP) server, "mail.com", is identical to your incoming server, your incoming user name will be used to access it. You can modify outgoing server settings by choosing Account Settings from the Tools menu.' At the bottom of the dialog are three buttons: 'Cancel', 'Back', and 'Next'.

- Review your email account's information. Click on **Finish**.

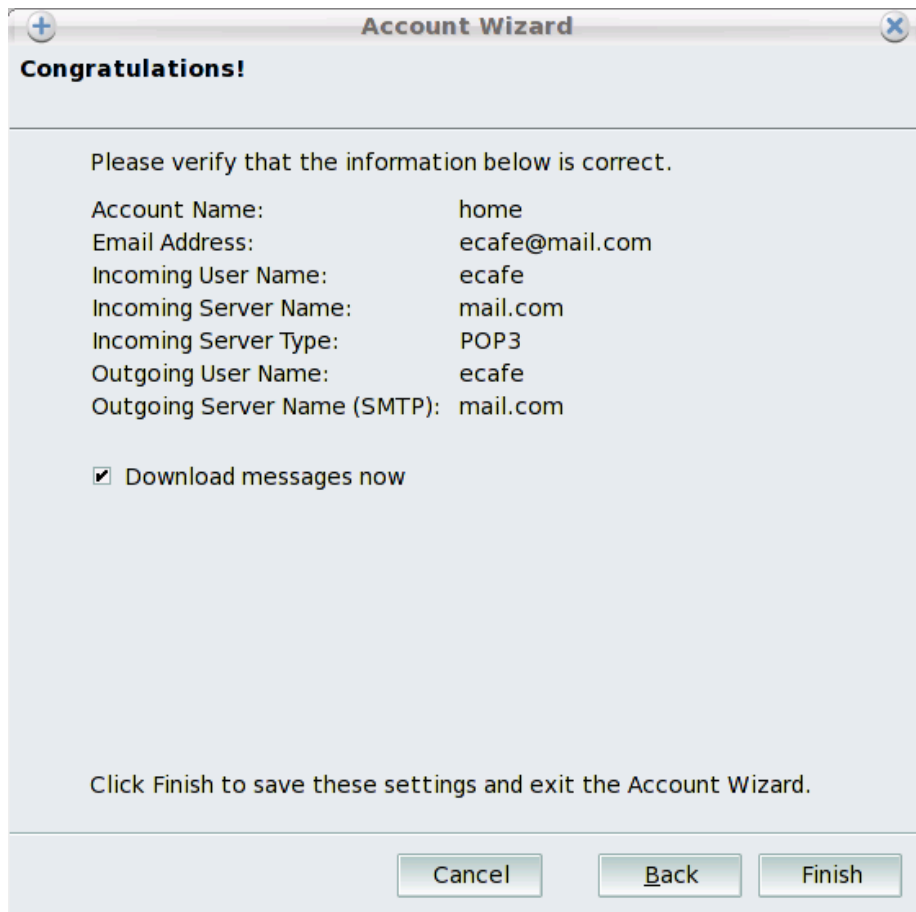

- Your email account appears onscreen.

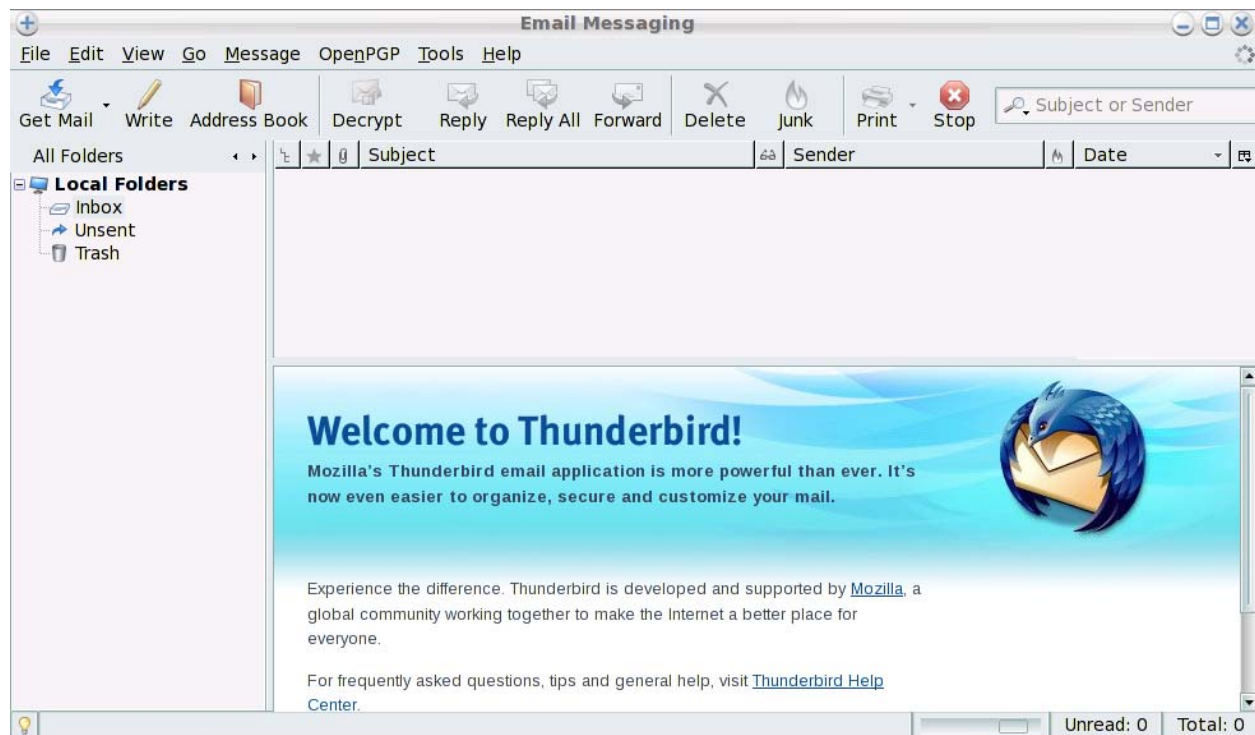

- To check if you've received any new emails, click on **Get Mail**. The system will ask you to provide your email login and password. If an error message displays, you can modify your email account's information by accessing **Edit–Account settings**.

Email

Window menu

Enables you to minimize or move the window, for instance, or move it to the foreground

Menu bar

Offers access to all features

Information regarding the message

Minimize, Reduce or Close the window



Check your new messages:

Checks outgoing and incoming messages

Addresses:

Opens the address book

Reply to a message mode:

Allows you to reply to the sender (Reply), to the sender and all recipients (Reply to all) or to transfer the message to the chosen recipients

Junk or Acceptable:

flags the selected file as Junk (suspicious content) or flags a Junk file as Acceptable

Stop:

Stops transferring a message



Write:

Opens a window in which you can type your message and add recipients and attachments

Unscramble:

Unscrambles or verifies the message using OpenPGP

Delete:

Deletes the message or the selected directory

Print:

Prints the selected message

Directory list

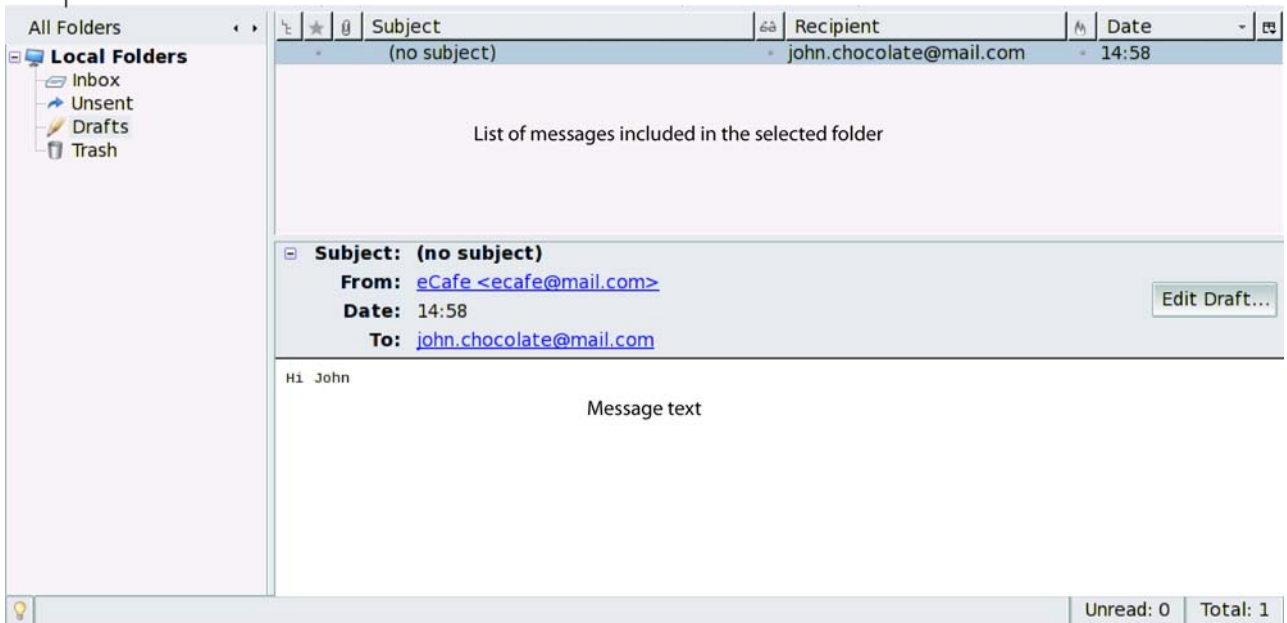

4.3 Chatting with friends

Instant messaging has become an essential communication tool, which allows you to chat in real time with your friends or colleagues (i.e. your **Contacts**). This is why the eCAFÉ™ features **Pidgin**, a multi-protocol instant messaging service that is compatible with the most common instant messaging applications.

The Pidgin configuration wizard launches when you first run the instant messaging application, in order to help you setup your instant messaging account.

1. Click on **Add**.



2. In the **Protocol** drop-down list, select your instant messaging service (e.g. MSN).

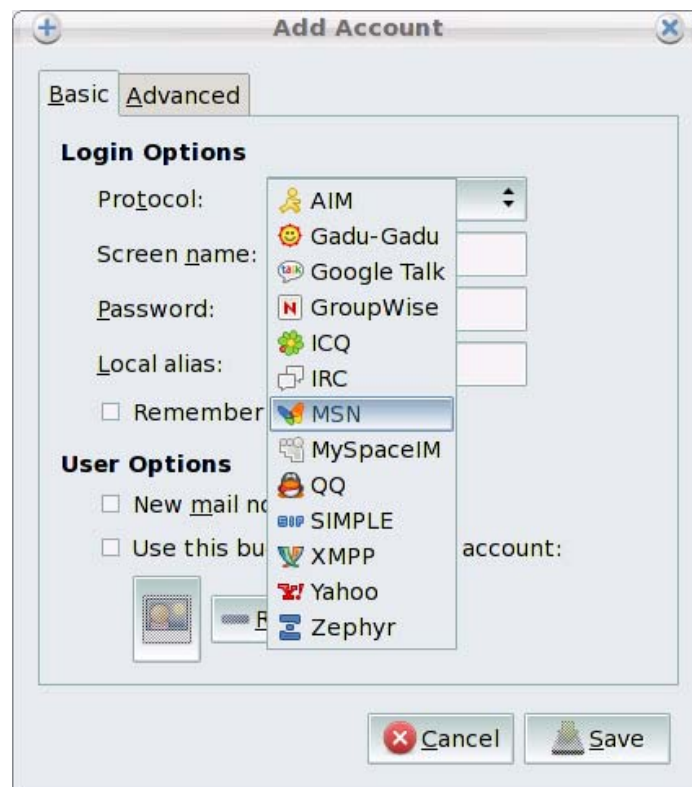

3. Enter your username, your password and a local nickname (i.e. the name that will appear in your friends' contacts list).



The screenshot shows the 'Add Account' dialog box with the following details:

- Protocol:** MSN
- Screen name:** john.cafe@msn.com
- Password:** [masked]
- Local alias:** my account
- Remember password
- New mail notifications
- Use this buddy icon for this account:
 - Image: [person icon]
 - Remove button

4. In the User options section, you can customise your account by adding an image. Check the **Use this buddy icon for this account** box and click on the suggested image to access the File Browser interface; then, select the image you wish to use in any of your directories.

5. Your instant messaging account's configuration procedure is almost finished. Click on **Save**.

6. Your instant messaging account appears onscreen.

Note: Your instant messaging account remains accessible via the icon located in the notification area, in the lower right-hand section of the screen, until you definitely close Pidgin.

Pidgin

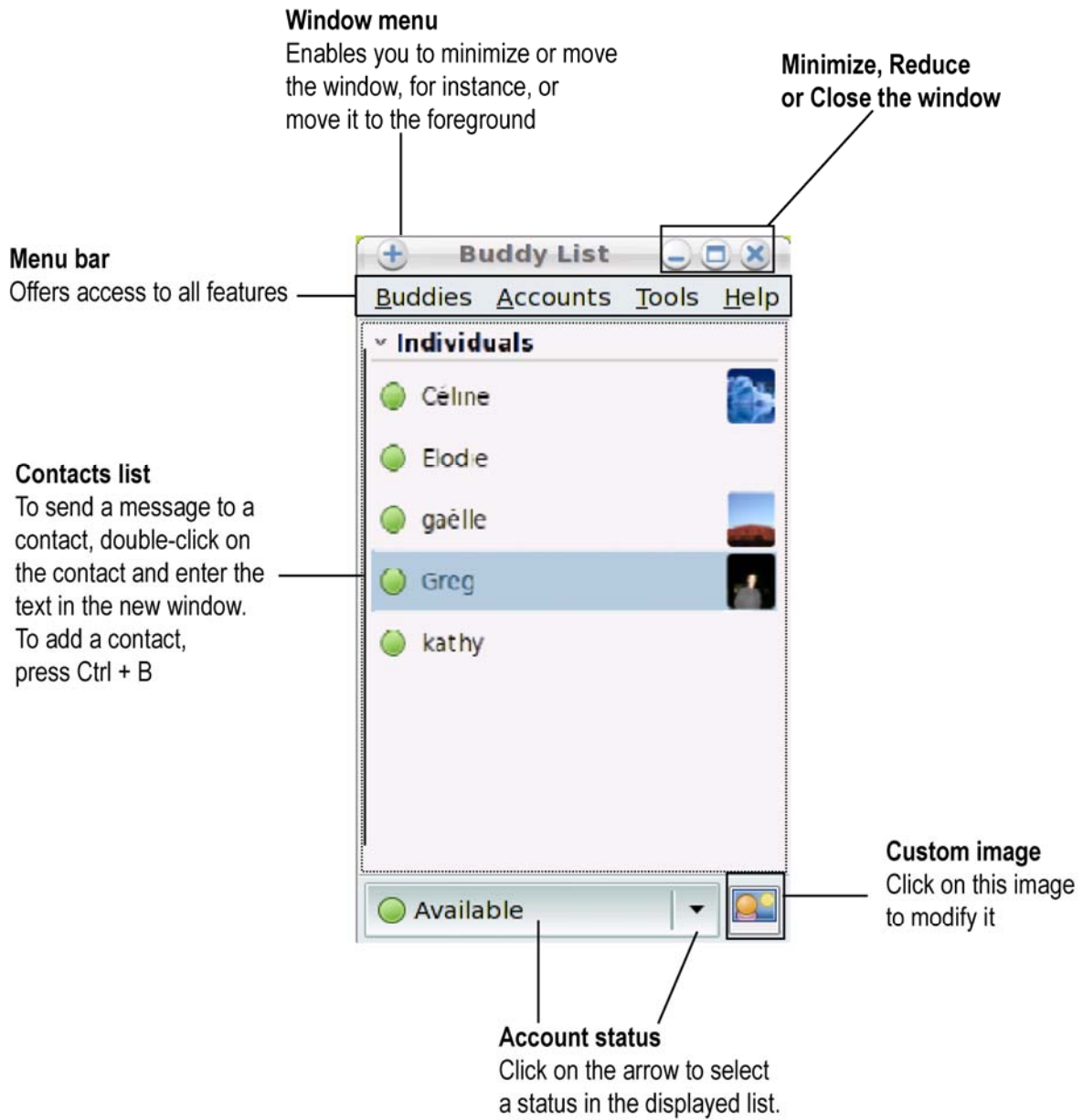

5. GAMES

Access the Games world.



The eCAFÉ™ offers a selection of popular games, as well as two games developed specially for your eCAFÉ™: Brain Challenge and Bubble Bash.

6. MULTIMEDIA

Access the **Multimedia** world.



6.1 Viewing and organising your photos



Launch the Photos application

Your eCAFÉ™ features a comprehensive photo management tool. You can import new photos, sort your photos by date or tag them in order to sort them by category.

Window menu

Enables you to minimize or move the window, for instance, or move it to the foreground

Menu bar

Offers access to all features

Application name

Minimize, Reduce or Close the window



Import:

Import images from the selected directory to the Images directory

Browse:

Display the images as thumbnails

Fullscreen:

Display the selected image fullscreen. Press the Esc key to revert to the thumbnail display.



Select an image and rotate it left or right

Modify the image:

Select an image and click on this button to access the editing options.

List of predefined tags

A tag is a marker that can be connected to an image or a group of images to make them easier to sort. Simply drag one of the tags onto the image.

Timeline

Once imported, the images are sorted by date (year and month). Click on one of the cells to display its contents. The more the cell is filled (in blue), the more images it contains. A white cell contains no images.

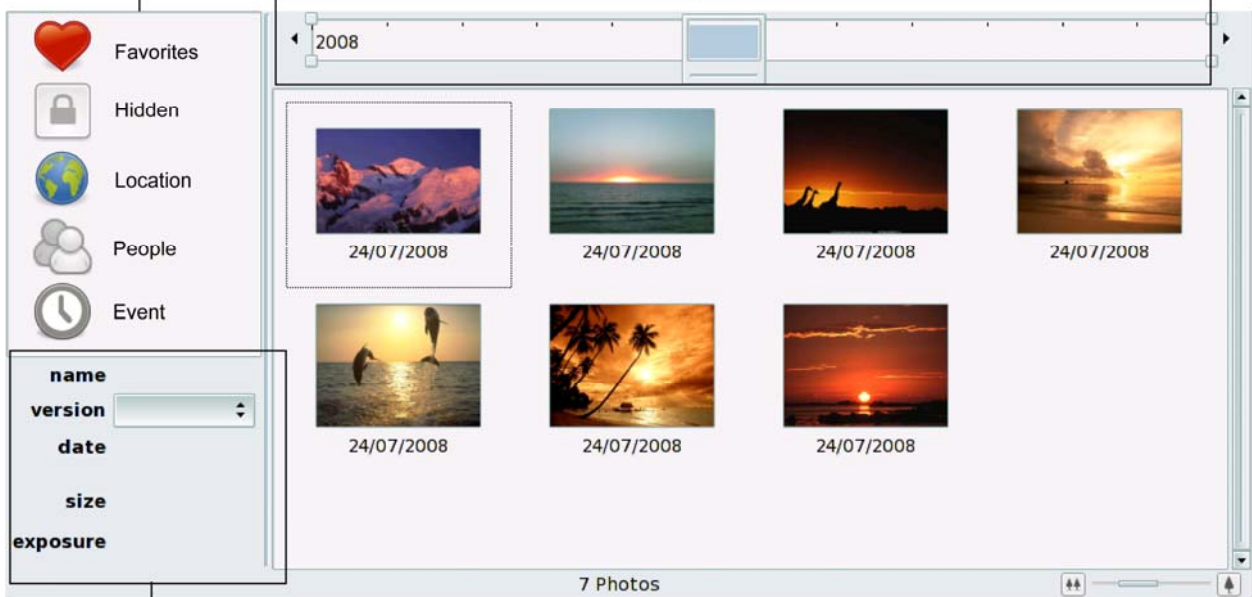

Information regarding the selected tag

6.2 Viewing videos



Launch the Videos application

Thanks to the multimedia player included on your eCAFÉ™, you can take your favourite movies with you and view your favourite videos and home-made holiday movies. To save time and access your favourite videos directly, you can also create playlists easily.

The multimedia player is compatible with MPEG, WMV and WMA formats and the most frequently video formats available on the Internet.

Window menu

Enables you to minimize or move the window, for instance, or move it to the foreground

Menu bar

Offers access to all features

Name of the loaded movie

Minimize, Reduce or Close the window



Movie menu

To load a movie, select Movie/Open, then access the movie file's location on the hard disk or an external storage peripheral (USB key etc.)

Playlist:

Displays the list of your favourite movies; you can access these instantly. Your movies can be stored on various storage media (hard disk drive, memory card, USB key). If the memory card or the USB key on which the movie is stored is not inserted in your eCafé™, you will not be able to read the movie.

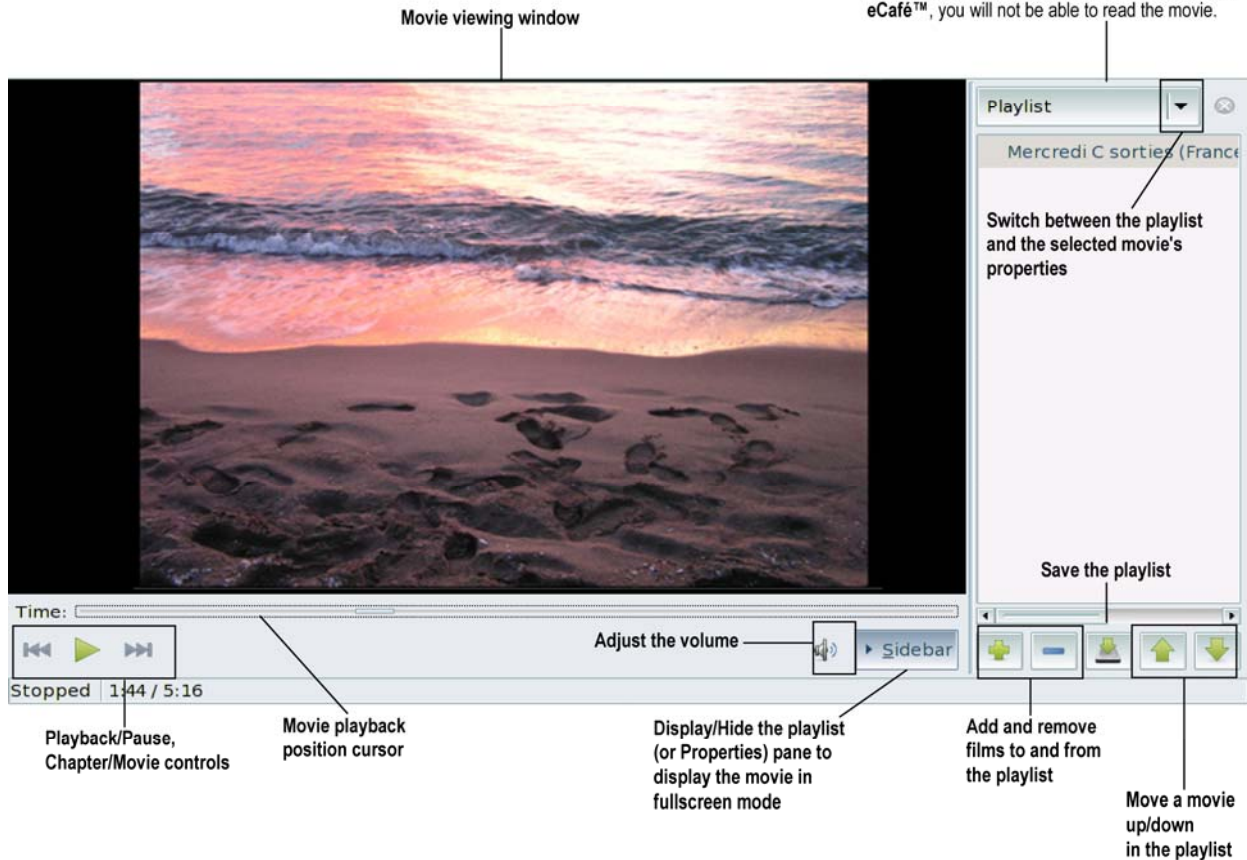

6.3 Listening to music



Launch the Music application

Enjoy a genuine digital music player including extensive playback, import and playlist creation functions. If you are constantly looking for new audio contents, subscribe to podcast streams and never miss your favourite radio program again, or create your own personal list of Internet radio stations.

Window menu
Enables you to minimize or move the window, for instance, or move it to the foreground

Menu bar
Offers access to all features

Album and track name

Minimize, Reduce or Close the window

Music menu
To load an audio file or a directory containing music files, select Music/Import a file (or Music/Import a directory), then access the file or directory's location on the hard disk drive or external storage device (USB key etc.)

Repeat:
Click here to resume playback of all tracks as soon as the last track ends

Shuffle:
Listen to the tracks in the order defined by the software

Adjust the volume

Playback/Pause, Next/Previous track controls

Track playback position cursor when playing a track

Information about the track (track name, album name)

Browse:
Switch between the simple and detailed track display modes

Track length

Quick access to libraries, shops, webradios and playlists

Specific track search area:
Enter part of the name or the full name to display all matching tracks

Search criteria:
Display the results matching all criteria (artists, albums and tracks) or only the albums, the artists or the tracks

The screenshot shows a music player interface with a search bar at the top containing the text 'artist'. Below the search bar, there are two panels: 'Artist' and 'Album'. The 'Artist' panel shows '1 artist (1)' with a sub-entry 'artist'. The 'Album' panel shows '1 album (1)' with a sub-entry 'album'. At the bottom, a table displays search results for tracks:

Track	Title	Genre	Artist	Album	Time
8	Title	Metal	Artist	Album	4:56

At the bottom left of the interface, it says '1 song, 4 minutes, 7.3 MB'. On the left side, there is a sidebar with 'Library' and 'Stores' sections. The 'Library' section includes 'Play Queue', 'Music', 'Podcasts', and 'Radio'. The 'Stores' section includes 'Jamendo' and 'Magnatune'. A CD icon is visible at the bottom left of the sidebar.

6.4 Using the webcam



Starting the webcam

Explore another side of digital communications thanks to the webcam built into your eCAFÉ™: take pictures and record video sequences with unrivalled ease thanks to the included software.

Webcam Station

Volume level when using the microphone: from 0 to 100%

Reduce or Close the window

Opens your webcam's Video settings control panel (brightness, contrast...).

Opens your webcam's Audio settings (microphone) control panel.

Allows you to access Webcam Station general settings (destination folder for recorded images and videos, file format...).

Affiche l'image de la webcam en plein écran. Appuyez sur la touche [F11] ou [Echap] du clavier pour revenir en mode normal.

Displays the version of the Webcam Station software, the copyright and the license agreement text.

Visualisation window
View the image captured by the webcam

Video recording underway

REC • 00 : 00 : 25

Open image folder

Open video folder

Enables or disables (mutes) the microphone

1 Mode selection

2 Resolution selection
2560 x 2048 (5M)

3 Capture

1. Select Photo or Video mode.

2. Select the resolution in the drop-down menu.

3. Press the button to take the photo or start the video recording.

4. Press the button to stop the video recording.

Hercules™

7. WORK

Access the **Work** world.



7.1 Creating, editing, saving and more

Included on your eCAFÉ™, OpenOffice is a user-friendly office application suite that allows you to create documents (e.g. letters, reports and more), simple or complex spreadsheets and elaborate slideshows.

In the Work world, you can click on the **Spreadsheet**, **Text** or **Slideshows** icons to directly access the required application. Regardless of the OpenOffice application in which you are working, you can create a **new** document (in this case, OpenOffice automatically switches to the relevant application) or **open** an existing document.

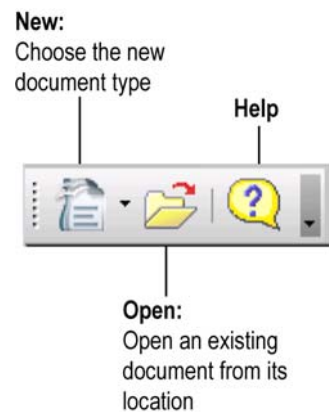

For further information regarding the selected application, please refer to the application's online help file; you can access this content by pressing on F1.

7.1.1 ...A document using OpenOffice.org Writer (word processor)

Window menu

Enables you to minimize or move the window, for instance, or move it to the foreground

Menu bar

Offers access to all features

Document name

Minimize, Reduce or Close the window



Styles and formatting:

Display or hide the available styles and formatting window

Styles, Font and Font size

Paragraph alignment:

Align left, centered, align right or justified

Increase or reduce paragraph indent

Highlighting: Highlights the selected text in the colour chosen in the palette



Font styles

Activate or deactivate bullet numbering

Save the file:

Select a location if you are saving the file for the first time

Quick print:

Print your document on the previously selected printer

Cut, Copy, Paste:

Select the text and transfer it (Cut) to the clipboard, or copy it (Copy) to the clipboard before inserting it (Paste) in another location

Cancel and redo:

Cancel the last action or redo a cancelled action

Non-printable characters:

Choose to display or hide characters such as spaces, paragraph marks etc.

Create a new file:

Text document, spreadsheet, slide show or others

File edit

Spellcheck

Table

Search and replace text automatically

Gallery



Open an existing file:

Search for a location on the hard disk drive or an external storage device (USB key, memory card)

Export directly as PDF file:

Export your file in a format readable on most computers

Auto Spellcheck:

Click to activate or deactivate the automatic spellcheck feature

Apply format:

Select the text, click on this button and apply the formatting to the new text

Hyperlink

Navigator

Data sources

Display the drawing features

Document as e-mail:

Send this document via a previously configured email account

Page preview:

Display a preview of your document before printing it

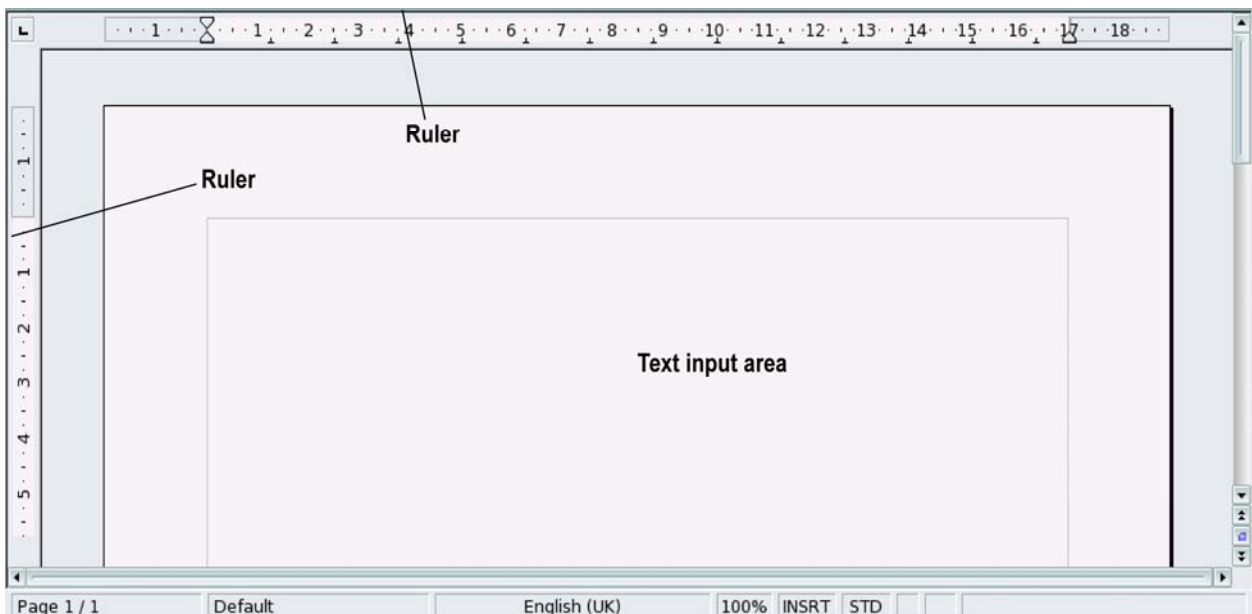

7.1.2 ...A spreadsheet using OpenOffice.org Calc (spreadsheet program)

Window menu

Enables you to minimize or move the window, for instance, or move it to the foreground

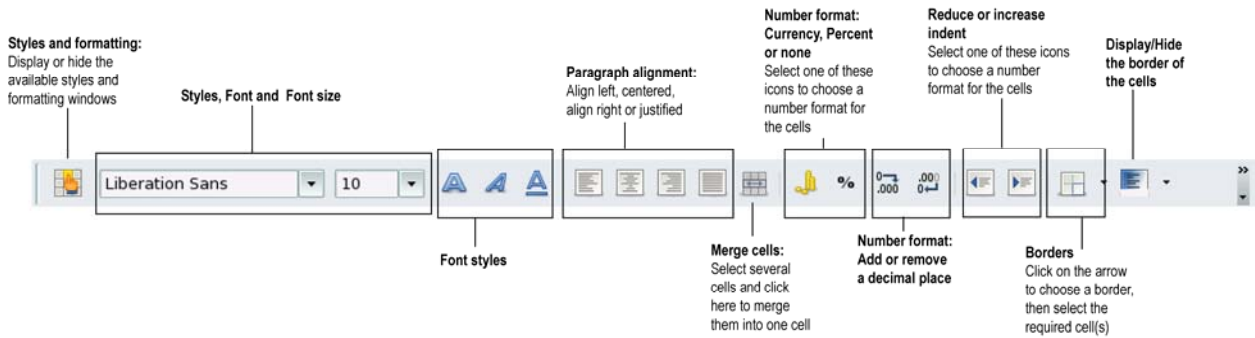
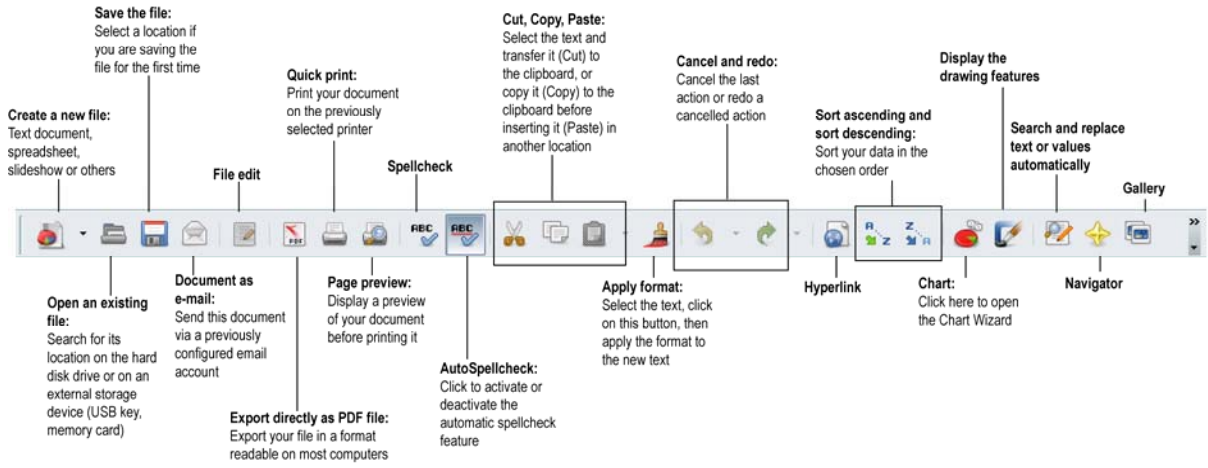
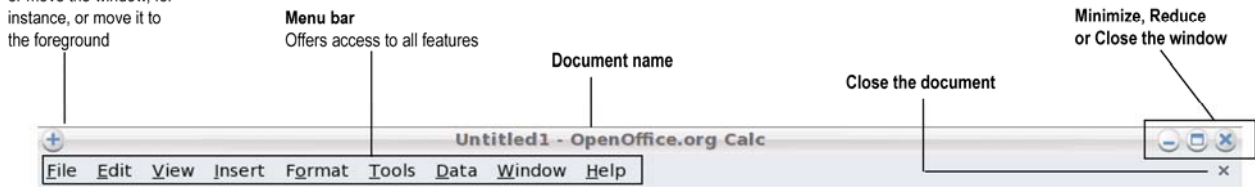

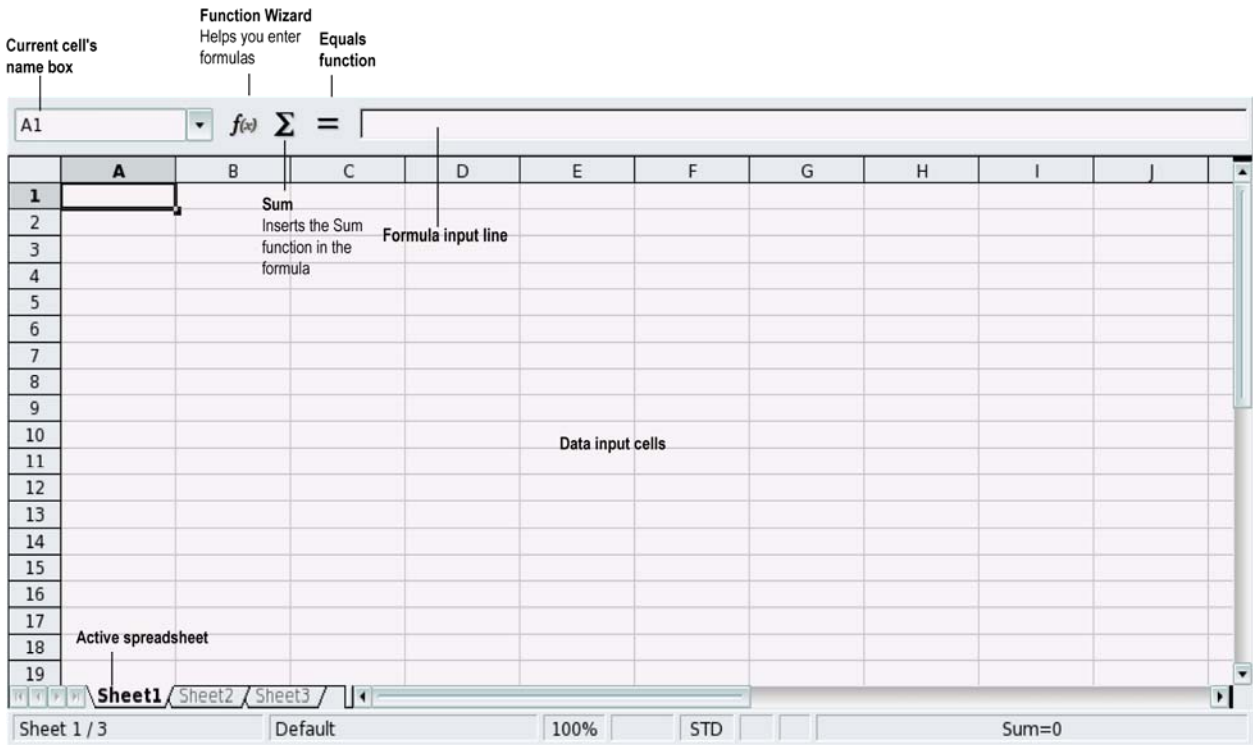

7.1.3 ...A slideshow using OpenOffice.org Impress (slideshow creator)

We shall now create a simple slideshow in 5 steps, using the **Presentation Wizard** that launches when you click on the Slideshows icon located on your desktop.

1. Create a slideshow **from a template**. Choose one of the available templates, then click on **Next**.

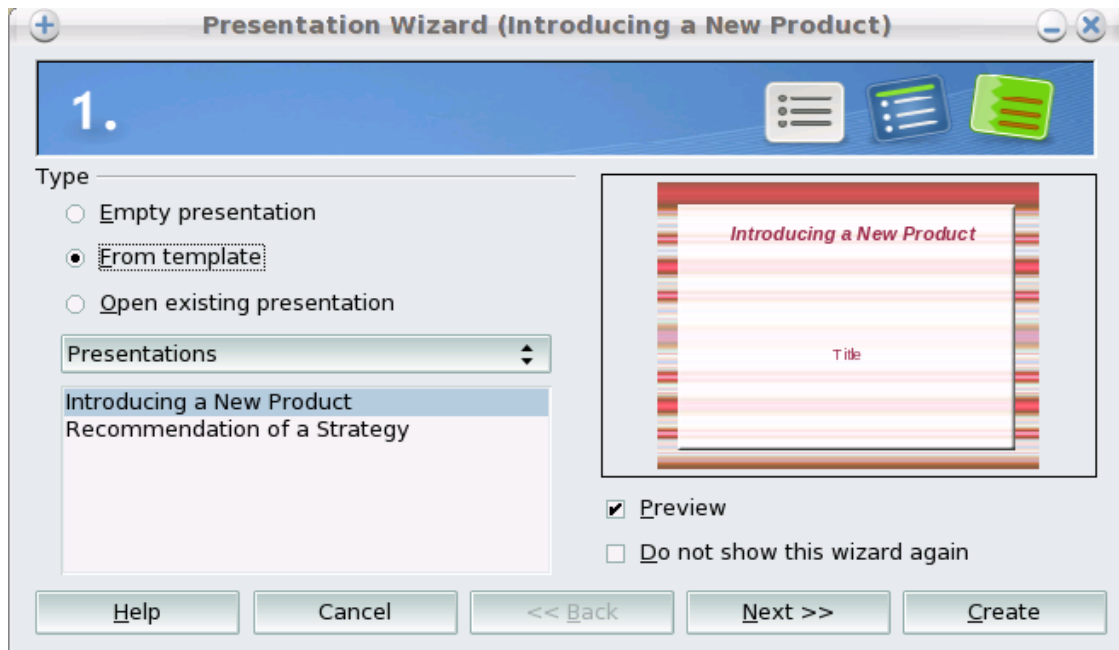

2. Choose your **background**. Click on **Next**.

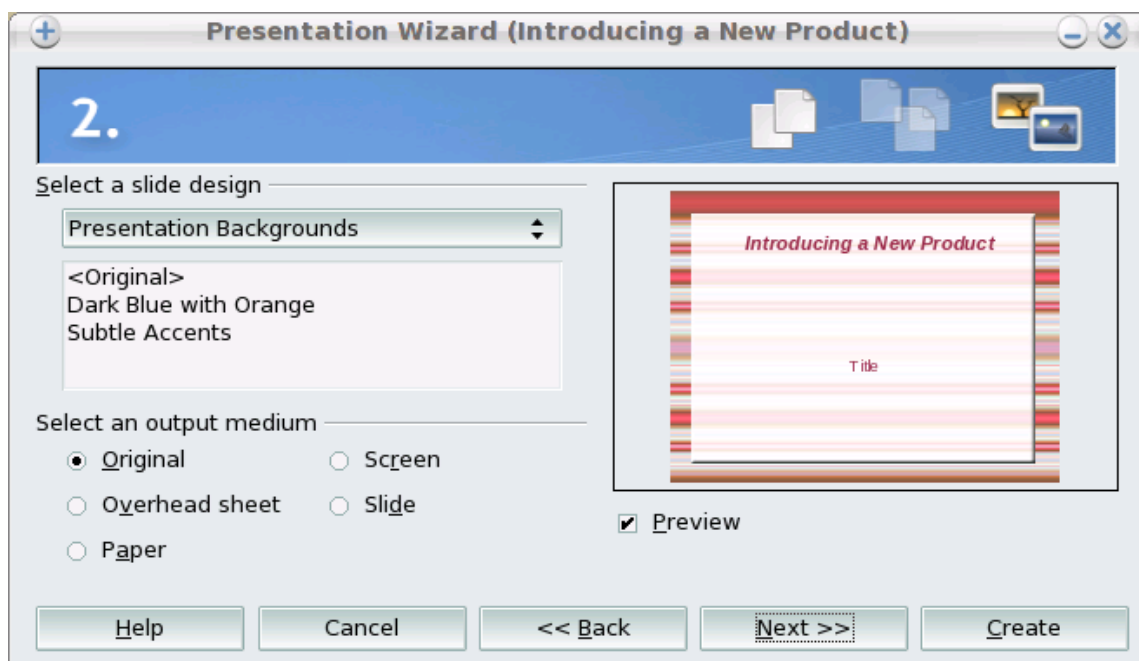

3. Select a **Slide transition** and the speed of the transition between two slides. Click on **Next**.



4. Enter the **information** that you wish to include in your slideshow. You will be able to amend this information after. Click on **Next**.



5. Select the pages that will comprise the structure of your slideshow. Click on Create.

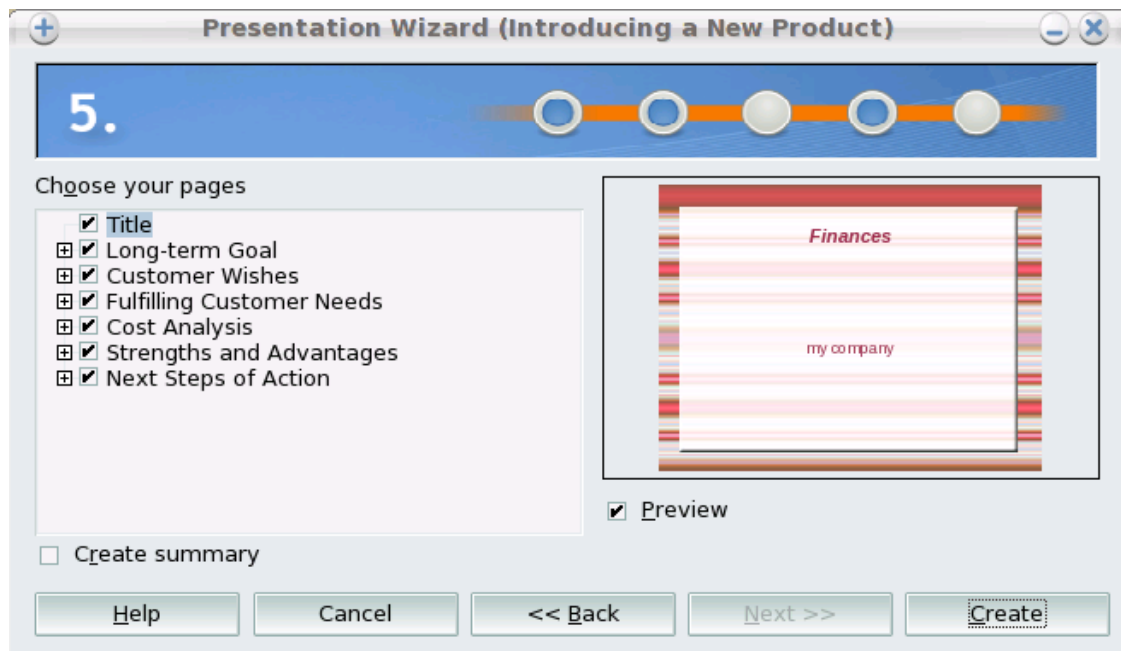

Your slideshow is now displayed in OpenOffice.org Impress. You can now finalise your presentation by creating objects, connectors, etc.

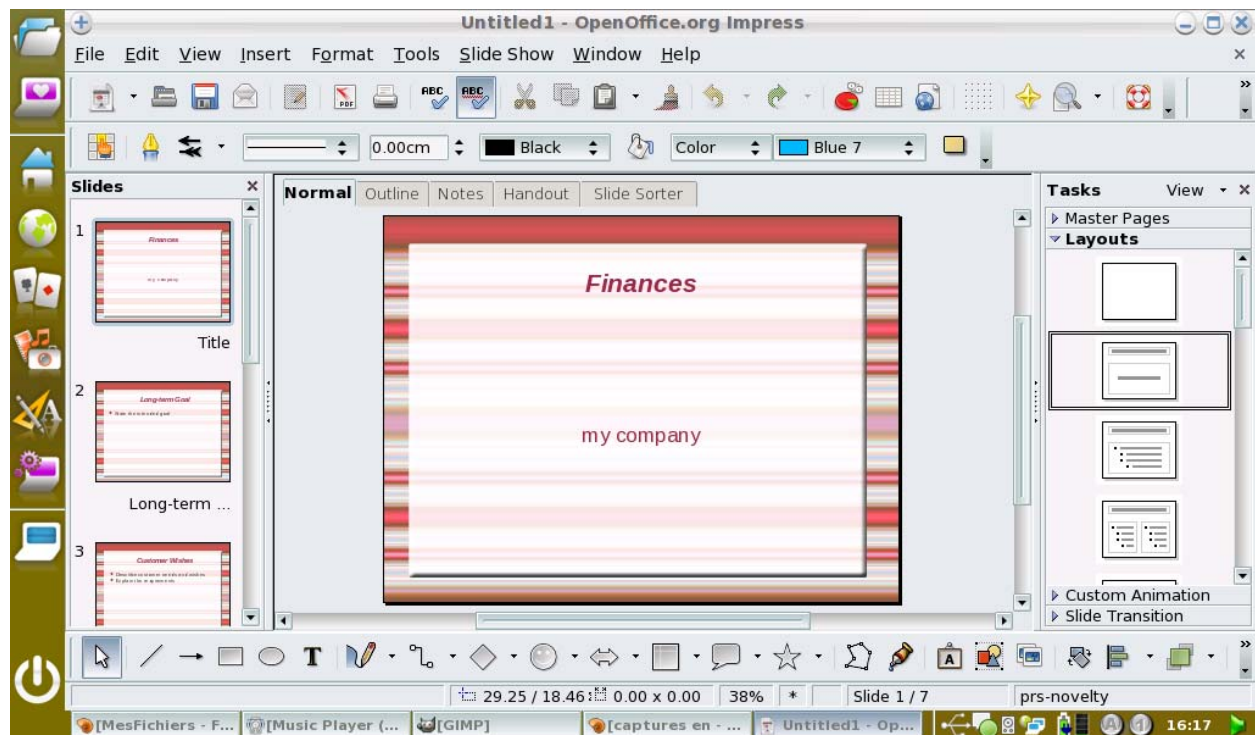

Window menu

Enables you to minimize or move the window, for instance, or move it to the foreground

Menu bar

Offers access to all features

Document name

Close the document

Minimize, Reduce or Close the window

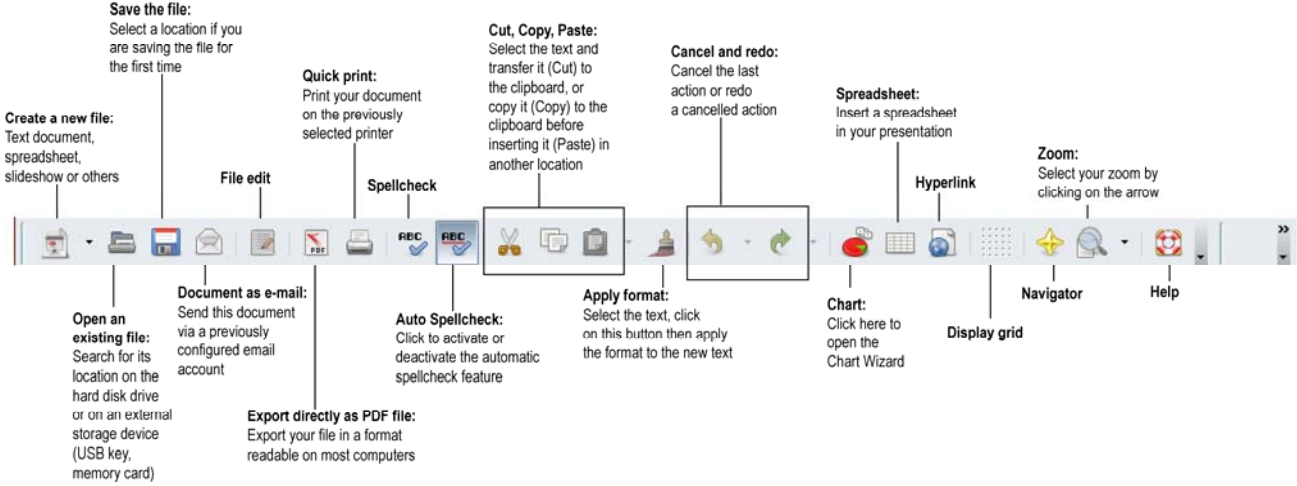
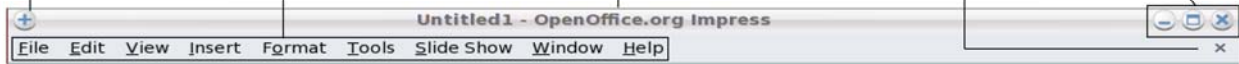

Styles and formatting:

Display or hide the available styles and formatting windows

Line creation parameters



Filling parameters of the selected object (a drawing for example)

Shadow: Click to add a shadow to the selected text

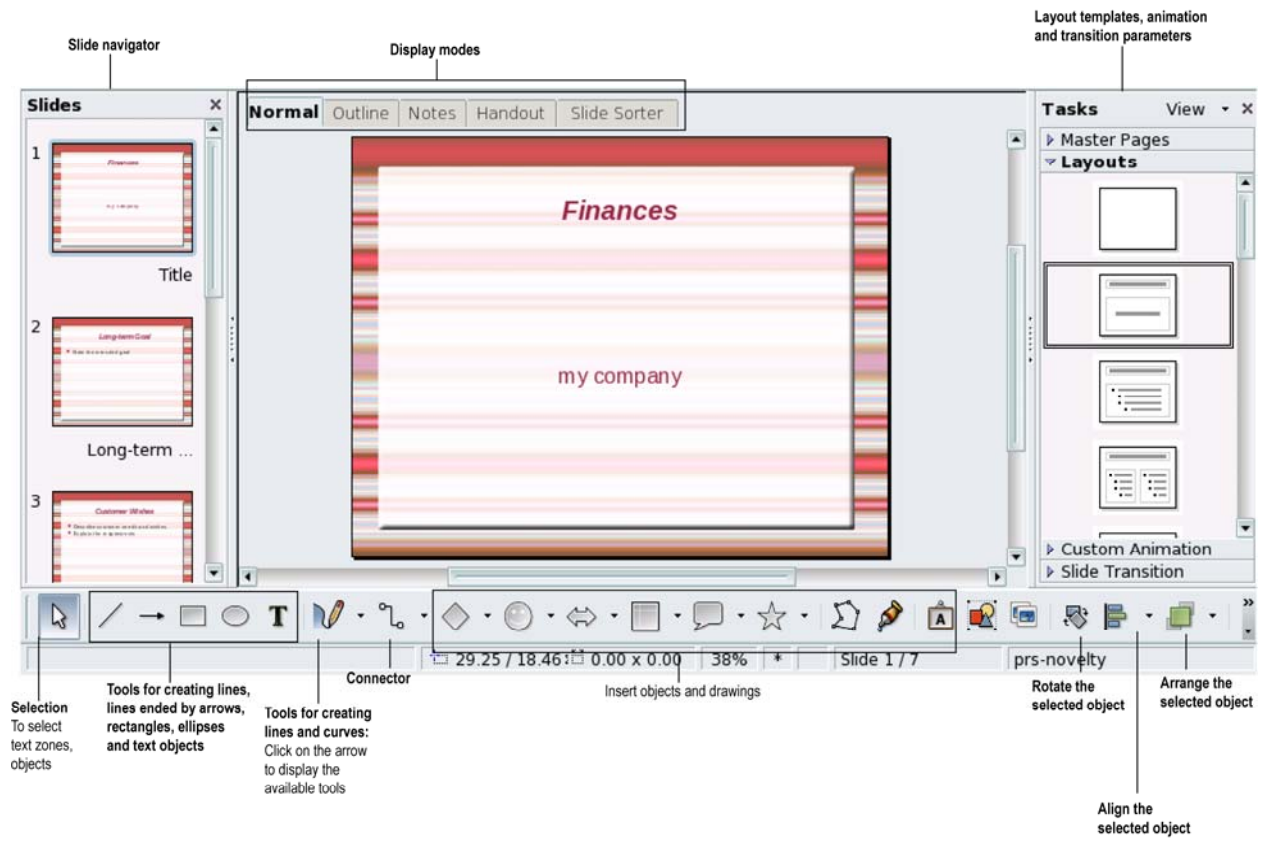

7.2 Managing your bank accounts

Manage your bank accounts from home with the HomeBank application provided with your eCAFÉ™.

Window menu

Enables you to minimize or move the window, for instance, or move it to the foreground

Menu bar

Offers access to all features

Document name

Minimize, Reduce or Close the window



Create a new file:

Text document, spreadsheet, slideshow or others

Save the file:

Select a location if you are saving the file for the first time

Edit payees:

Add or remove payees to whom you can issue bank transfers, etc.

Edit archives:

Manage your wallet's information

View the operations on the selected account:

View all operations performed on the selected account over a given time range



Open an existing file:
Search for a location on the hard disk drive or an external storage device (USB key, memory card)

Edit accounts:
Add or remove accounts

Edit categories:
Add or remove expense categories

Edit budget:
Manage your budget according to the defined categories

Accounts summary

Account	State	Bank	Today	Future
▼ Bank accounts				
		£ 100,000.00	£ 101,100.00	£ 101,100.00
my account		£ 100,000.00	£ 101,100.00	£ 101,100.00

Accounts and operations visualisation windows

Upcoming automated transactions

Payee	Description	Amount	Next on	Remaining

7.3 Managing your schedule

The **Schedule** application allows you to take your schedule with you, to make sure that you will never forget an important event. You can very quickly fill in your tasks list or manage your schedule (meetings, appointments etc...) over several weeks.

Window menu

Enables you to minimize or move the window, for instance, or move it to the foreground

Menu bar

Offers access to all features

Information about the document

Minimize, Reduce or Close the window

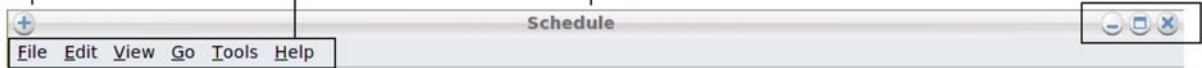

Create a new task:

Add a task to your tasks list

Display mode:

Today, Day, Week, Several weeks, Month

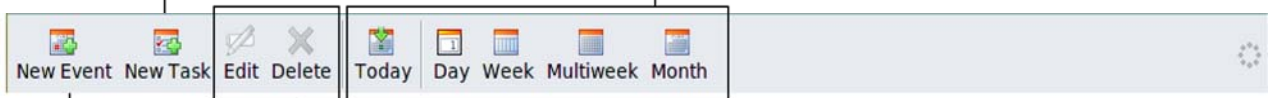

Create a new event:

Create an event (meeting, conference etc.), that will be inserted in the calendar

Edit or delete

selected element (event or task)

Current calendar **List of calendars** **Display settings:** Display all events, the events for today, the events scheduled in 7 days... **Event search area:** For instance, enter "for" to display only "forum" events

Title	Start	End	Category
meeting	Tue 25 Mar 2008 16:00	Tue 25 Mar 2008 17:00	Business
forum	Fri 14 Mar 2008 16:00	Fri 14 Mar 2008 17:00	

Results matching the criteria above

Wednesday Thursday **Friday** Saturday Sunday

14 Mar
Friday

08:00
09:00
10:00
11:00
12:00
13:00
14:00
15:00
16:00 forum

Tasks list

Hide Completed Tasks

! Title

meeting

8. INSTALLING APPLICATIONS



To install new applications or updates on your eCAFÉ™ netbook, you must connect to the Internet via a WiFi connection or use the Ethernet port to connect to a modem, an Internet box or a corporate network connected to the Internet, for instance. Your netbook will use this connection to search for all available applications on a dedicated server.

To install new applications or updates, access the **Settings** world, then click on **Computer Configuration**.

The **Control Centre** displays. Select the **Software Manager** thumbnail, then click on the **Add and remove software** thumbnail.



Before allowing the installation, the application may request that you enter the user account password (the default password is "ec-900") and the administration account password (the default password is "root").

- Select the relevant applications category in the list: Office, Development, Graphics, etc.

Packages (lists of applications) matching the selected category are displayed.

- Select a package to view its description.

- Check the box to select the package that you wish to install.

- You can also install the required additional packages, if necessary.

- Click on **Apply**.

- Confirm the installation by clicking on **Yes**.

9. SAVING AND RESTORING DATA

In the following sections, you will learn how to create backups on various types of storage media and learn how to restore your data using these backups. You can also connect to the www.hercules.com website. In the section dedicated to the eCAFÉ™, you will find all the relevant information required to create your backups.



We also recommend that you frequently create backups of any personal or sensitive data that you may have stored on your netbook.

9.1 Creating backups on a USB key

- Connect the USB key to one of the two available USB ports. The eCAFÉ™ automatically detects the newly connected device.
- In the File Browser, select the files and/or directories that you wish to backup (hold the  key to select several consecutive files, or hold the Ctrl key to select several non-consecutive files).
- In the **Edit** menu, select **Copy**.
- In the File Browser, click on the name of your USB key (which now appears in the left-hand pane).
- Choose the destination location for the files.
- In the **Edit** menu, select **Paste**.

9.2 Creating backups on a memory card

- Insert the memory card in the memory card reader. eCAFÉ™ automatically detects the newly connected device.
- In the File Browser, select the files and/or directories that you wish to backup (hold the  key to select several consecutive files, or hold the Ctrl key to select several non-consecutive files).
- In the **Edit** menu, select **Copy**.
- In the File Browser, click on the name of your memory card (which now appears in the left-hand pane).
- Choose the destination location for the files.
- In the **Edit** menu, select **Paste**.

9.3 Creating backups on a CD or DVD

- Connect a CD/DVD drive to one of the two available USB ports. The eCAFÉ™ automatically detects the newly connected device.
- Launch the application **External CD/DVD Drive** using the quick access icon.
- Create a backup project.
- In the File Browser, select the files and/or directories that you wish to backup (hold the  key to select several files in a row, or hold the Ctrl key to select several non-consecutive files).
- Click on the **Add** button.
- Insert a blank CD or DVD in the CD/DVD drive.
- Click on the **Burn** button.

9.4 Restoring backup data from a USB key

- Connect the USB key to one of the two available USB ports. The eCAFÉ™ automatically detects the newly connected device.
- In the File Browser, click on the name of your USB key (which now appears in the left-hand pane).
- Select the files and/or directories that you wish to restore (hold the  key to select several files in a row, or hold the Ctrl key to select several non-consecutive files).
- In the **Edit** menu, select **Copy**.
- In the File Browser, select a destination location for your files.
- In the **Edit** menu, select **Paste**.

9.5 Restoring backup data from a memory card

- Insert the memory card in the memory card reader. eCAFÉ™ automatically detects the newly connected device.
- In the File Browser, click on the name of your memory card (which now appears in the left-hand pane).
- Select the files and/or directories that you wish to restore (hold the  key to select several files in a row, or hold the Ctrl key to select several non-consecutive files).
- In the **Edit** menu, select **Copy**.
- In the File Browser, select a destination location for your files.
- In the **Edit** menu, select **Paste**.

9.6 Restoring backup data from CD or DVD

- Connect an external CD/DVD drive to one of the two available USB ports, and insert the CD or DVD containing your backup data. The eCAFÉ™ automatically detects the newly connected device.
- In the File Browser, click on the name of the CD/DVD drive (which now appears in the left-hand pane).
- Select the files and/or directories that you wish to restore (hold the  key to select several files in a row, or hold the Ctrl key to select several non-consecutive files).
- In the **Edit** menu, select **Copy**.
- In the File Browser, select a destination location for your files.
- In the **Edit** menu, select **Paste**.

INDEX

A	
Audio	7
Audio connectors.....	9
B	
Background image	23, 28
Battery	1, 2, 3, 4, 5, 10, 11, 12, 13, 25
Installing or removing.....	11
C	
Control Centre	27, 28, 59
D	
Display modes	
Full screen	7
Window	7
E	
eCAFÉ™ Connect.....	1, 26, 27, 29, 30, 31, 32
eCAFÉ™ galaxy.....	1, 14, 18
eCAFÉ™ portal	18, 19
Email Messaging.....	32, 33, 37
F	
File Browser	19, 23, 25, 60, 61
Forcing the computer to shut down or restart	15
H	
Hard disk drive	8
Hard drive.....	3
Home.....	14, 18, 19, 23, 28
I	
Instant Messaging	38, 39, 40
L	
Local Area Network.....	9
M	
Manage your bank accounts.....	56
Memory card drive	3, 5, 8
MMC	3, 8
SD.....	3, 8
SD HC	3, 8
Multifunction keyboard.....	1, 2, 3, 4, 7, 8, 31, 32
Music.....	1, 16, 45
N	
Netbook... 1, 2, 3, 4, 8, 9, 13, 14, 15, 16, 18, 19, 29, 31, 32, 59, 60	
P	
Password	2, 36, 39, 59
Personalisation Wizard	7, 15, 19, 23, 28
Photos	1, 25, 43
S	
Schedule	58
Security key	30, 31
Shutting the device down.....	15
Slideshow creator	1, 52
Spreadsheet program	1, 50
T	
Turning the device on	14
U	
USB ports.....	3, 5, 8, 16, 25, 60, 61
V	
VGA connector.....	15
Video.....	3, 9, 17, 23, 44, 47
W	
Webcam.....	1, 3, 4, 47
WiFi feature.....	1, 2, 7, 13, 26, 27, 29, 30, 31
Word processor.....	1, 49
World	
Communications.....	14, 18, 19, 20, 26, 29
Games.....	14, 18, 19, 20, 41
Multimedia	14, 18, 19, 21, 42
Settings.....	14, 18, 19, 22, 27, 28, 59
Work	14, 18, 19, 21, 48

WARNING



Read the following warnings before you or your child play video games.

Always observe the following recommendations when playing video games.

Avoid playing if you are tired or lacking sleep.

Always play in a well-lit room, and reduce the brightness of your screen.

When playing a video game on a television screen, sit at good distance from the screen, as far away the connection cable will allow.

When playing a video game, stop playing for ten to fifteen minutes every hour.

About photosensitive epileptic seizures

Some people may experience a seizure with loss of consciousness or loss of sight when exposed to intense visual stimulation, such as series of flashing images or the repeated display of simple geometrical shapes, flashing lights or explosions.

These persons are prone to experience photosensitive epileptic seizures when playing video games featuring such visual stimulation, even if they have no history of seizures or epilepsy.

If you, or anyone in your family, have already experienced an epileptic condition (seizure or loss of conscience) when subjected to the visual stimulation described above, consult your physician before using a video game.

Parents should look out for, or ask their children about, the above symptoms - children and teenagers are more likely than adults to experience these seizures. These seizures may have a variety of symptoms including light-headedness, altered vision, eye or face twitching, jerking or shaking of arms or legs, disorientation, confusion or momentary loss of awareness. Should you or your children experience any of the above, stop playing immediately and consult a physician.

TECHNICAL SUPPORT

If you have trouble using your device or one of its components, please connect to the <http://ts.hercules.com/fr> website and select your language. Here, you will be able to access different services (Frequently Asked Questions (FAQs), the latest versions of all available drivers and software) that may help you solve your problem. If this fails to solve the problem, please get in touch with Hercules' Technical Support.

Via email:

To reach our Technical Support via email, you must first register online on the <http://ts.hercules.com/eng/index.php> website. The information that you provide will help our technicians solve your problem as swiftly as possible.

Click on **Online Support - FAQ**, then on **Visit the Technical Support website**, then click on **Product registration** and follow the instructions provided onscreen..

By telephone (if you do not have Internet access):

United Kingdom	08450800942 Charges at local rate	Monday to Friday from Noon to 4pm and 5pm to 10pm Saturday from 9am to Noon and 1pm to 7pm Sunday from 9am to Noon and 1pm to 4pm
-----------------------	---	---

Connect to the Hercules website (www.hercules.com/fr) now to download the latest versions of all available drivers and software, view the Frequently Asked Questions (FAQs) relevant to your product and download the latest upgrades of your product's User Manual. You can also discover the extensive range of Hercules products and download information about the forthcoming releases.

WARRANTY INFORMATION

Guillemot Corporation S.A. ("Guillemot") guarantees consumers worldwide that this Hercules product is free from material and manufacturing defects for a period of two (2) years beginning on the original date of purchase. Should the product seem defective during the period covered by the warranty, please contact our Technical Support immediately for further information on how to proceed. After contacting our Technical Support, if it appears necessary to return the product to us, please return the product and its accessories in the original packaging, well packaged and protected, according to the instructions provided by our Technical Support.

According to the terms of this warranty, following our Technical Support's decision, the defective product may be repaired or replaced. When authorised by applicable law, any liability incurred by Guillemot and its subsidiaries (including consequential damages) will be limited to repair or replacement of the product manufactured by Hercules. The consumer's statutory rights on account of applicable law on the sale of consumer goods are not affected in any way by this warranty.

This warranty will not apply:

(1) If the product has been modified, opened, altered in any way or damaged by inappropriate or abusive use, negligence, an accident or normal wear; (2) If the product has been used or stored in abnormal conditions (e.g. exposition to adverse weather conditions, to direct sunlight, to water or to sand); (3) For any other reason not relating to a material or manufacturing defect; (4) In the event of non-observance of the instructions provided in the User Manual or by our Technical Support; (5) To any software not edited by Guillemot, said software being covered by a specific warranty granted by the software's editor; (6) If the warranty seals have been removed or altered in any way; (7) For damages to or the loss of programs, data or storage media, or for the costs arising from the retrieval of said data; (8) For damages to or the loss of programs or personal data occurring after repair or replacement of the product; (9) For damages caused by the installation of third-party software or by computer viruses.

Guillemot shall in no event be held responsible for any damage to or loss of personal data, programs, software or removable storage media. Before returning this program to Technical Support, please create a backup of any personal and/or sensitive data. Guillemot shall in no event be held responsible for reinstalling or retrieving personal data or programs other than those installed at the time of the product's commercialisation.

The warranty applies to your product's display if the display features at least 5 defective pixels (i.e. bright spots or dark spots, a bright spot being a white pixel permanently displayed on the screen, and a dark spot being a pixel that does not display on the screen.)

In the event where the product is returned to our Technical Support and the warranty cannot be applied owing to the presence of one or several of the exclusion conditions stated above, the incurred shipping and processing costs will be charged to the consumer.

Registered trademarks

Hercules® and eCAFÉ™ are registered trademarks of Guillemot Corporation S.A. Mandriva® is a registered trademark of Mandriva S.A.. Mozilla® is a registered trademark of Mozilla Foundation. RealNetworks® and RealPlayer® are registered trademarks of RealNetworks Inc. Fluendo is a registered trademark of Fluendo S.A. Corel® is a registered trademark of Corel Corporation. OpenOffice.org® is a registered trademark of Sun Microsystems Inc. Windows®, Windows XP®, Windows Vista® and the Windows logo are trademarks or registered trademarks of Microsoft Corporation in the United States and/or other countries of the world. Intel®, Intel® Atom™ and Intel® Atom™ Inside are registered trademarks of Intel Corporation in the United States and other countries of the world. WiFi Certified & WiFi Protected Setup are registered trademarks or brands of the WiFi Alliance. All other registered trademarks and brand names are hereby acknowledged and are the property of their respective owners. Illustrations not binding. Contents, designs and specifications are liable to change without prior notice and may vary according to countries.

Made in China

Statement of Compliance with EU Regulations

Guillemot Corporation S.A. hereby declares that the device *UMPC EC-900-H60G-IA* complies with the with the main requirements and other relevant clauses of Directive RTTE 1999/5/CE, of Directive CEM 2004/108/CE and with the standards relating to electrical security (IEC 60950, 2001 Edition / EN 60950-1, 2001 Edition / NF EN 60950, Amendment A11-2004). The compliance statement can be viewed on the following website:

ftp://ftp.hercules.com/EC-900/H60G-IA/DoC-fra_UMPC_EC-900-H60G.pdf



Copyright

© 2008 Guillemot Corporation S.A. All rights reserved.

No part of this manual may be copied, summarised, issued, posted, stored in a search engine or translated in any language or computer language, for any purpose or by any means that may be, whether electronic, mechanical, magnetic, manual, by means of photocopies, recordings or others, without the express authorisation in writing of Guillemot Corporation S.A.

End User License Agreement

IMPORTANT: Please read the following End User License Agreement before using the eCAFÉ™ device. The term "Software" refers to all executable programs, managers, libraries, data files and to any documentation relating to the programs, as well as the complete operating system included in the eCAFÉ™ product. The Software is licensed, and not sold, to the User, exclusively for use complying with the terms of this License Agreement. The Software is comprised of free software sub-applications provided by the Free Software Foundation (applications, product administration programs, etc.), which are sub-licensed by Guillemot Corporation S.A. under the conditions described in point 5 above. You hereby accept and agree to abide by the Terms & Conditions of this License Agreement. If you disagree with the Terms & Conditions of this License Agreement, please do not use the Software.

The Software is protected by international copyright laws and agreements, as well as other international laws and agreements relating to intellectual property.

The Software (excluding the software sub-applications) remains the property of Guillemot Corporation S.A. All rights reserved. Guillemot Corporation S.A. grants only a limited and non-exclusive right to use the Software.

Guillemot Corporation S.A. reserves the right to cancel this License Agreement in the event of failure to abide by its Terms & Conditions.

License granted:

1. The license is granted to the original Buyer alone. Guillemot Corporation S.A. remains the sole owner and holder of the Software (excluding the software sub-applications), and reserves all rights that are not expressly granted by this License Agreement. The User is not allowed to sub-license the rights granted by this License Agreement. The User is allowed to transfer this License, provided that the original Buyer retains no part of the Software and that the Transferee reads and accepts the Terms & Conditions of this License Agreement.
2. The Buyer may only use the software on one computer at a time. The machine-readable part of the Software may be copied to another computer, provided that the Software is deleted from the first computer and that it is impossible to use the Software on several computers at the same time.
3. The Buyer hereby acknowledges and accepts the copyright belonging to Guillemot Corporation S.A. The copyright shall in no event be removed from the Software, nor from any documentation, whether printed or electronic, provided with the Software.
4. The License grants the User the right to perform one (1) copy of the machine-readable part of the Software for archival purposes, provided that the User also copies Software's copyright.
5. The free software sub-applications provided by the Free Software Foundation and sublicensed by Guillemot Corporation S.A. are subject to the Terms & Conditions of the General Public License (GPL), which is available at the following address: <http://fsf.org/gpl/gpl-fr.html>. The source codes of these software sub-applications are available at the following address: <http://www.hercules.com/fr>. Some of these software sub-applications have been modified by Guillemot Corporation S.A. (the list of these software sub-applications is available on the following website: <http://www.hercules.com/fr>).
6. Except within the limits expressly allowed by this License Agreement, the Buyer may not agree or allow any third party to agree to: grant a sublicense; provide or divulge the Software to other third parties; allow use of the Software on several computers at a time; perform alterations or copies of any kind; reverse engineer, decompile or modify the Software in any way or attempt to obtain information relating to the Software that is not accessible to the User; perform copies or translations of the User Manual.

Warranty limitation:

The Software is provided "as is", with no guarantee whatsoever from Guillemot Corporation S.A. regarding its use and/or performance. Guillemot Corporation S.A. does not guarantee that the operation of the Software will be free from interruptions or errors. The use or the performance of the Software remain under the Buyer's entire responsibility, and Guillemot Corporation S.A. can provide no guarantee of any kind with regard to the performance and results obtained by the Buyer while using the Software. No guarantee of any kind, whether explicit or implied, is offered by Guillemot Corporation S.A. with regard to the non-violation of third party rights, the merchantability or the adequacy of the Software to a specific use.

In no event shall Guillemot Corporation S.A.'s liability be engaged in the event of damages of any kind arising from the use or the incapacity to use the Software.

Applicable law:

The Terms & Conditions of this License Agreement are subject to French Law.

ENVIRONMENTAL CARE RECOMMENDATIONS

At the end of its useful life, this product should not be discarded with standard household refuse but should be given to a collection point for waste from electric and electronic devices, where it shall be recycled.

This is stated by the symbol that appears on the product, the User Manual or the packaging.

According to their specificities, these materials may be recycled. By supporting recycling and other methods of recovering waste from electric and electronic equipment, you help care for the environment.

Please consult with the local authorities, who will refer you to the relevant waste collection point.