

# CONTENTS

<b>1. eCAFÉ™ – TAKE IT TO GO!™</b> .....	<b>2</b>
1.1. Handling your Netbook .....	2
1.2. A comprehensive package .....	3
1.3. A closer look at your eCAFÉ™ .....	3
<b>2. THE eCAFÉ™, UNEQUALLED AND UNRIVALLED</b> .....	<b>4</b>
2.1. My eCAFÉ™ .....	4
2.2. Turning the eCAFÉ™ on .....	5
2.3. Technical specifications .....	6
2.4. Multifunction keyboard .....	8
2.5. An ultra-mobile computer suited to large files .....	9
2.6. Extensive connectivity options for countless applications .....	9
2.7. A desktop device AND a mobile device .....	11
2.7.1. <i>Operating the eCAFÉ™ when connected to the mains</i> .....	11
2.7.2. <i>Operating the eCAFÉ™ with the built-in battery</i> .....	12
2.7.3. <i>Installing and removing the battery</i> .....	12
2.7.4. <i>Optimising your use of the battery</i> .....	14
2.8. Shutting your eCAFÉ™ down .....	14
<b>3. FIRST STEPS WITH MY eCAFÉ™</b> .....	<b>16</b>
3.1. Welcome to the eCAFÉ™ galaxy! .....	16
3.2. Connecting an external display .....	17
3.3. Mastering the touchpad .....	18
3.4. Accessing the online help and tutorials .....	18
3.5. Extensive contents to take you further .....	19
3.6. Connecting to the Internet .....	20
3.6.1. <i>eCAFÉ™ Connect and the WiFi feature</i> .....	20
3.6.2. <i>Using the Microsoft Zero Config utility to establish a connection to the WiFi network</i> .....	24
3.6.3. <i>Connecting to the Internet via a DSL network or a Local Area Network (LAN)</i> .....	25
3.7. Sending and receiving emails .....	26
3.8. Chatting with friends .....	27
3.9. Using the webcam .....	27
3.10. Work .....	28
3.10.1. <i>Creating, editing and saving a document using OpenOffice.org Writer (Word processor)</i> .....	28
3.10.2. <i>Creating, editing and saving a spreadsheet using OpenOffice.org Calc (Spreadsheet)</i> .....	30
3.10.3. <i>Creating, editing and saving a slideshow using OpenOffice.org Impress (Slideshow)</i> .....	32
3.11. Saving data to a removable media (USB key, memory card) .....	37
3.12. Protection software for your eCAFÉ™ .....	37
<b>INDEX</b> .....	<b>38</b>
<b>TECHNICAL SUPPORT</b> .....	<b>38</b>
<b>WARRANTY INFORMATION</b> .....	<b>39</b>

# 1. eCAFÉ™ – TAKE IT TO GO!™

Thank you for trusting Hercules and choosing to purchase the eCAFÉ™ Netbook. The eCAFÉ™ has been designed to allow you to communicate and create or edit documents such as text files, slideshows or even images; it also includes advanced multimedia features designed to entertain you.

To make the most of your eCAFÉ™ Netbook, please follow the instructions provided in this manual.

## 1.1. Handling your Netbook



Please read this section with care before using the product.

Like any electronic device, the eCAFÉ™ requires you to observe a number of simple safety rules; these are listed below. In addition, observing some simple precautions will enable you to extend your eCAFÉ™'s life.

- In no circumstance should you attempt to open the eCAFÉ™, its adaptor or its components; doing this would expose the device's internal components to damage. Likewise, never attempt to open the device's batteries.

- Use only the adaptor provided with the product.

- Always place your eCAFÉ™ on a horizontal, stable and flat surface.

- Never exert pressure on the display. Never touch the display with any objects that are liable to damage it or scratch it.

- Always make sure that you have removed any objects placed on the device's keyboard (e.g. USB key, pen or others) before closing your eCAFÉ™'s display.

- To avoid any risk of fire or electric shock, always keep your eCAFÉ™ away from:

- Rain or moisture, as well as all fluids (water, chemical products and any other liquids),

- Heat sources such as radiators, cookers or other heat-emitting devices (including amplifiers),

- Direct sunlight.

- This product should be used only at temperatures ranging from 5 to 35°C.

- Never cover your eCAFÉ™ while the device is powered on.

- Always unplug your eCAFÉ™ before cleaning it. To clean it, use a soft cloth; avoid using chemical sprays.

- The eCAFÉ™ provides a WiFi wireless connection feature. Use of this feature is liable to cause interferences with the equipment located on planes or in hospitals. Always deactivate this feature before entering these premises.

- Always deactivate the WiFi feature during thunderstorms.

- Never throw the device's batteries into an open fire.

- When transporting the eCAFÉ™, always turn the device off if you are carrying it in a closed bag. As a general rule, make sure that your eCAFÉ™ is placed in a well-vented environment when the device is powered on.

## 1.2. A comprehensive package

Compact design, an ultra-lightweight device, powerful connectivity, various accessories included. Discover the packaging contents:

- eCAFÉ™ Netbook
- Battery
- Power adaptor
- Quickstart guide

## 1.3. A closer look at your eCAFÉ™

- 1.6 GHz VIA C7-m processor
- 1 GB DDR2 (SO-DIMM) RAM
- 8.9" backlit LCD display (max. native resolution 1024\*600)
- 300,000 pixel built-in webcam, built-in microphone
- Built-in Intel® 945GSE graphics board, built-in sound board
- Built-in 802.11 b/g/N WiFi board
- 120 GB 2.5" SATA hard disk drive
- 2200 mAh rechargeable Lithium battery (3 cells)
- Power adaptor

Enertronix, Inc.	EXA0901XH	Input: AC 100-240 V, 50-60 Hz, 1,0 A Output: 19 V  , 2,1 A	CB (JPTUV-022291-M3)
------------------	-----------	--	----------------------

- 2 USB 2.0 ports (compatible with USB 1.1 devices)
- 10/100Mbps Ethernet port
- VGA output
- 1 headphones connector, 1 microphone connector
- 84-key keyboard
- Touchpad featuring 2 buttons
- Multiple-format memory card reader: SD (Secure Digital®), SD HC (Secure Digital® HC), MMC (MultiMedia Card)
- Weight: 1.2 Kg approx. (battery included)
- Dimensions: 251 mm x 185 mm x 31 mm

Your eCAFÉ™ EC-900B/H120G/VW features the Microsoft® Windows® XP Home Edition operating system. It can be enriched with the installation of applications compatible with this system. In no event shall Guillemot Corporation S.A.'s liability be bound in the event of damages of any kind (including, but not limited to the loss of data) resulting from the installation or use or incorrect use of these applications.

## 2. THE eCAFÉ™, UNEQUALLED AND UNRIVALLED

The eCAFÉ™ Netbook features a very wide range of applications and extensive connectivity interfaces, which will enable you to instantly connect to the world that is best suited to your use: work, communications, games or multimedia.

### 2.1. My eCAFÉ™

- Remove your eCAFÉ™ from the packaging, and ensure that all items mentioned in Section 1.2 of this User's Manual are included.

- Remove the protection films from the display.

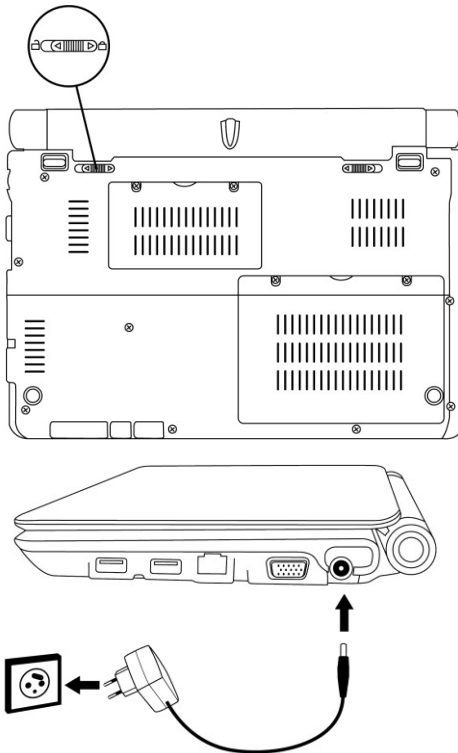

- Insert your battery (for more information regarding battery installation and removal, please refer to Section 2.7.3).

- Connect the power adaptor lead to your eCAFÉ™, then connect the adaptor to the mains.

## 2.2. Turning the eCAFÉ™ on

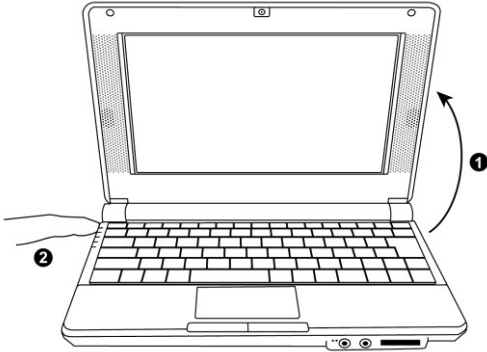

- Open the display (1) and press the On/Off button located on the right-hand side of the device (2).



Do not exert excessive strength on the hinges when opening the display. Do not hold your eCAFÉ™ by the display when carrying the device.



When your computer starts up, the Home world is displayed; this page is the starting point of your journey throughout the eCAFÉ™ galaxy.

## 2.3. Technical specifications

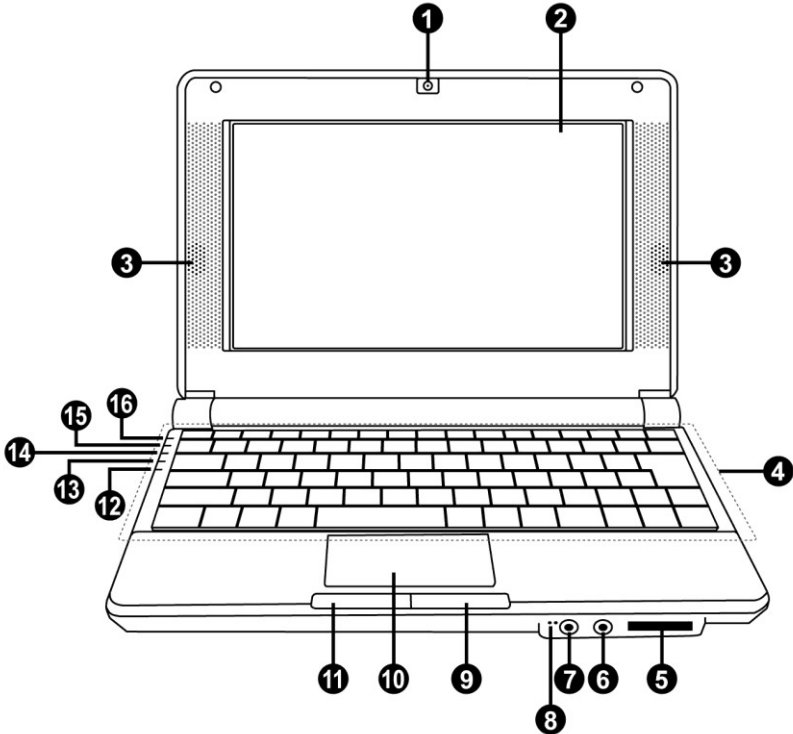

- |                       |                          |  |
|-----------------------|--------------------------|--|
| 1. Webcam             | 6. Microphone connector  | 12. Headphones connector               |
| 2. 8.9" LCD display   | 7. Headphones connector  | 13. Battery operation indicator        |
| 3. Speakers           | 8. Microphone            | 14. WiFi activity indicator            |
| 4. Keyboard           | 9. Right touchpad button | 15. Hard disk drive activity indicator |
| 5. Memory card reader | 10. Touchpad             | 16. Mains operation indicator          |
|                       | 11. Left touchpad button |  |

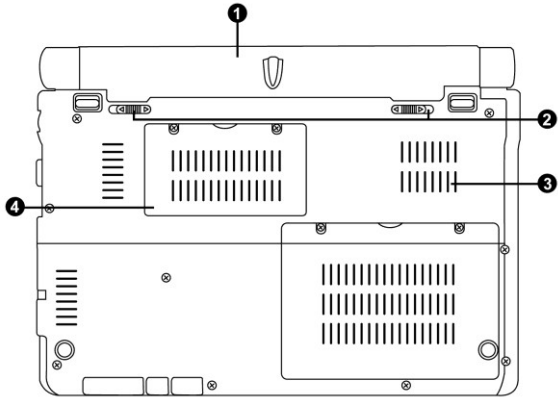

- 1. Removable battery
- 2. Battery locking tabs
- 3. Air extraction grate
- 4. DDR RAM location



This part of your eCAFÉ™ is liable to heat during operation and charging. This is normal. However, to improve thermal dissipation, we recommend you do not block the vents. Avoid placing your eCAFÉ™ on a soft surface such as a sofa or a bed, for instance.

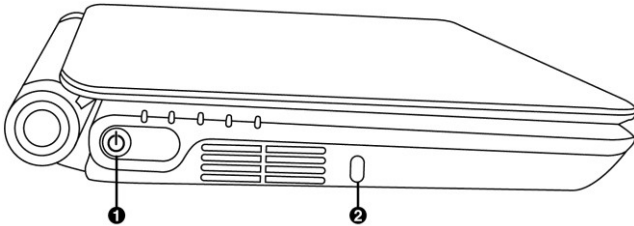

- 1. ON/OFF button
- 2. Kensington® lock

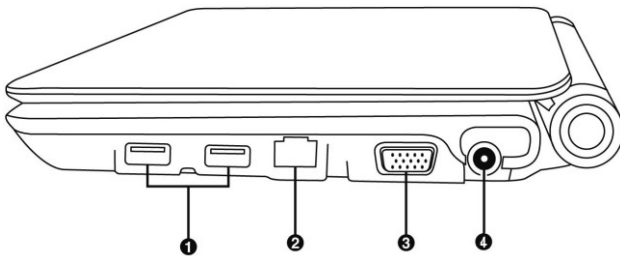

- 1. USB 2.0 ports
- 2. LAN/Ethernet port
- 3. VGA output connector
- 4. Power supply port

## 2.4. Multifunction keyboard

The eCAFÉ™ features an extended keyboard allowing you to control the display's settings and the WiFi connectivity features.

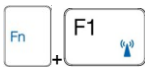

Activate/Deactivate WiFi feature (default is inactive)



Reduce volume



Activate/Deactivate audio output



Increase volume



Activate/Deactivate touchpad



Suspend the computer



Switch from the LCD display to an external display



Lock/Unlock number pad



Reduce display brightness



Lock/Unlock the display scrolling feature



Increase display brightness



Switch from fullscreen display to windowed display in internet browser



## 2.5. An ultra-mobile computer suited to large files

Equipped with a hard disk drive and a multiple-format card reader, the eCAFÉ™ enables you to take your most precious files with you, regardless of their size.

### Hard disk drive

The eCAFÉ™ features a 120 GB (or more, according to versions) hard disk drive. This storage capacity allows you to save movies, images and other large files to your device.

### Memory card reader

The eCAFÉ™ is equipped with a multiple-format memory card reader supporting SD (Secure Digital®) and SD HC (Secure Digital® HC), MMC (MultiMedia Card) formats; this device enables you to view pictures taken with your digital camera or to extend your system's storage capacity, for instance.

### USB ports

The eCAFÉ™ is also equipped with two USB ports that enable you to connect a USB storage key or other USB devices (for further information regarding USB ports, please refer to section 2.6, "Extensive connectivity options for countless applications").

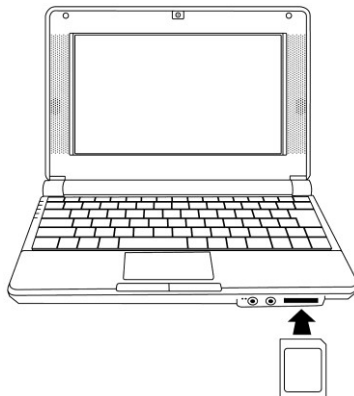

## 2.6. Extensive connectivity options for countless applications

The ports and connectivity interfaces built into your eCAFÉ™ enable you to connect all kind of USB peripherals, such as a mouse or an external hard disk drive, to your ultra-mobile personal computer.

### General safety rules

Before connecting a peripheral to your Netbook, please refer to the installation instructions provided with the device.



Never remove a peripheral while your eCAFÉ™ is reading or saving data; you would risk destroying the data beyond repair.

### USB ports (Universal Serial Bus)

The eCAFÉ™ features two USB 2.0 ports (USB 1.1 compatible), to which you can connect many peripherals such as a keyboard, a mouse, a USB key and more. This interface is hot-swappable, allowing you to connect and remove your peripheral without having to first shut it down.

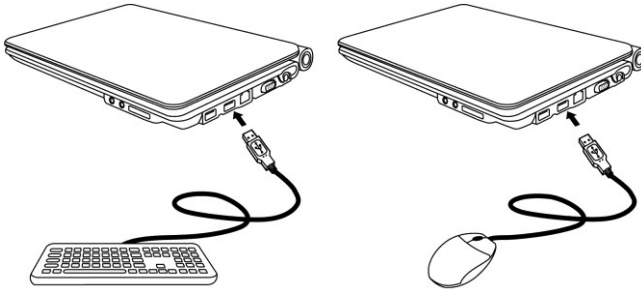

If you have connected a USB external hard disk drive to your eCAFÉ™, please click on the  icon (located in the lower right section of the screen) and select "Remove media" prior to disconnecting your peripheral.



The system may fail to recognise some USB peripherals if they have been connected during the computer's start-up phase. Should this be the case, please remove the device from your Netbook and connect it again.

### Audio connectors

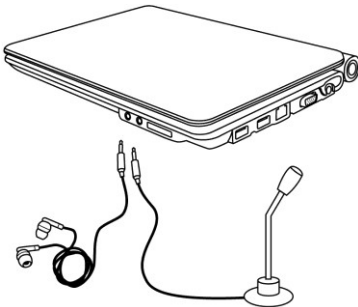

To initiate a communication or view a video, please connect a microphone, headphones and/or a headset featuring a built-in microphone to the relevant connector:

- The jack output connector to connect headphones or a headset
- The jack input connector to connect an MP3 player for recording purposes, or a microphone to record vocal data or chat with your contacts using a voice-over-IP application

## Local Area Network (LAN)

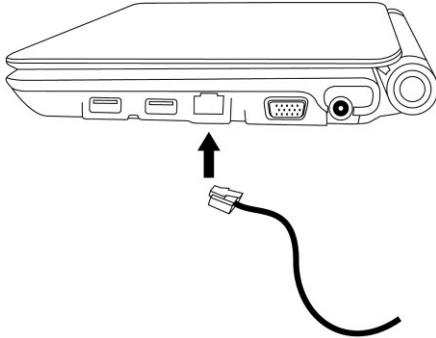

The eCAFÉ™ is equipped with a RJ45 LAN connectivity interface, which enables you to connect it to a 10/100 Mbps wired network (corporate network, router, wired modem & router or Internet box, for instance).

## 2.7. A desktop device AND a mobile device

Both a desktop device and a mobile device at once, the eCAFÉ™ can be used everywhere thanks to its dual power supply (mains or battery).

### 2.7.1. Operating the eCAFÉ™ when connected to the mains

Use the included power adaptor to power your eCAFÉ™. The device complies with the specifications of the electric network in the country in which the device was purchased.



Please make sure that the power supply plug is fully engaged into the computer's power supply connector.

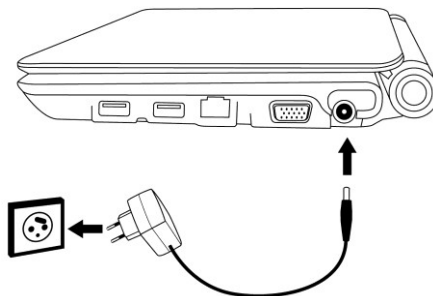

When the eCAFÉ™ is connected to the mains, the device's battery starts to charge automatically. Please note that fully charging the eCAFÉ™ while the device is in use requires more time than when the eCAFÉ™ is turned off.

### 2.7.2. Operating the eCAFÉ™ with the built-in battery

The eCAFÉ™ is designed to operate on its built-in battery. When fully charged, the built-in battery guarantees ample autonomy (about 2 hours\*).



To extend your battery's lifespan, we recommend that you charge it fully when using your eCAFÉ™ for the first time. Please refer to the battery charge status indicator for more information regarding the battery charge level.

\* Autonomy is liable to vary according to your use of the eCAFÉ™ (applications, network conditions).

### 2.7.3. Installing and removing the battery

You may need to install or remove the battery, e.g. when replacing the battery.



Before installing or removing the battery: first, place the **locking tabs ❶** in the "Unlocked" position; install or remove the **battery ❷**, then place the locking tabs in the "Locked" position again.

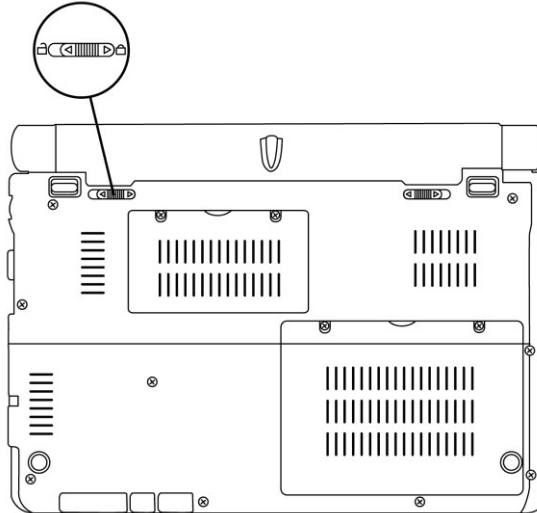

Always shut your eCAFÉ™ down before installing or removing the battery!



Use only **Hercules** batteries that are fully identical to the original batteries included with your eCAFÉ™. Failure to comply with these instructions may cause damage to your eCAFÉ™. Likewise, the use of an inappropriate battery may cause a risk of explosion. Please dispose of used device batteries according to the instructions and applicable regulations.

### Installing the battery

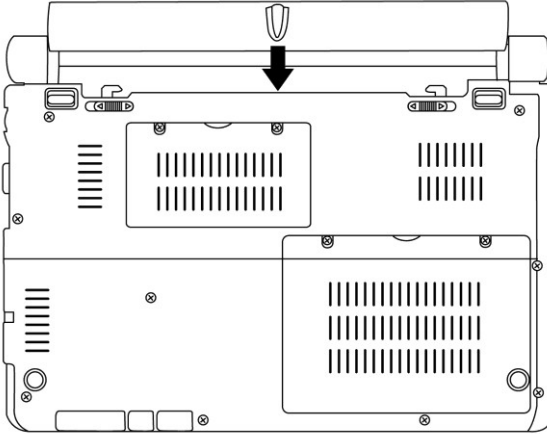

### Removing the battery

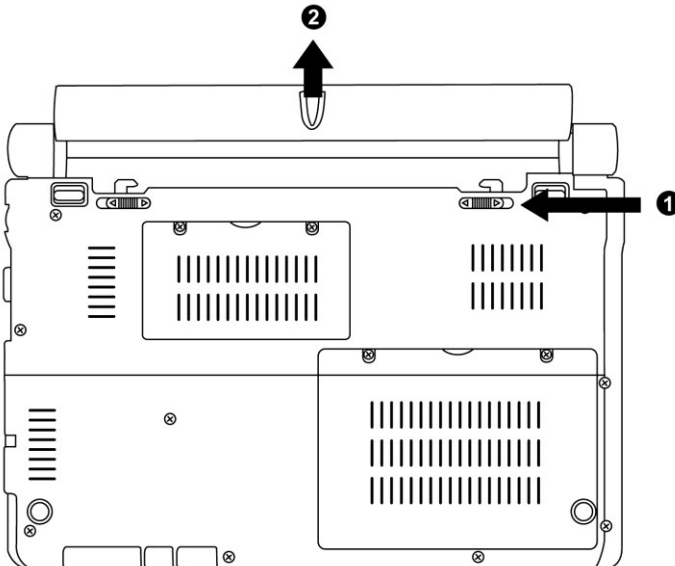

## 2.7.4. Optimising your use of the battery

Your Netbook's lithium-ion (Li-Ion) battery may be charged at any time. The device must be stored in a room in which the temperature ranges from 5 to 35°C, and should not be left in a vehicle parked in direct sunlight.

To extend the battery's lifespan:

- Adjust the display's luminosity to a level suited to your environment (indoors/outdoors) and to the application that you are using.

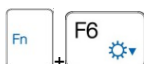

Reduce display  
brightness



Increase display  
brightness

- Close the display when you are not using your eCAFÉ™ for a short time. The display will automatically turn off.
- When using your eCAFÉ™ for the first time, always charge the battery entirely.
- Deactivate the WiFi feature if you are not accessing a WiFi network.

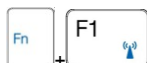

Deactivate the WiFi feature

## 2.8. Shutting your eCAFÉ™ down

### Shutting the device down

- Before shutting your eCAFÉ™ down, make sure that all your programs and applications have shut down tidily.
- Shut your eCAFÉ™ down by clicking on the Start menu in the lower left-hand section of the screen, then select **Shut computer down**.

### Screensaver mode

Your eCAFÉ™'s display automatically switches to the Screensaver mode when not in use for a certain time. Press on a key or on the touchpad to reactivate it.

### Forcing the computer to shut down or restart

If you have trouble starting your computer up, press the device's On/Off button and hold it down until your eCAFÉ™ shuts down.

If an unexpected configuration prevents your eCAFÉ™ from reverting to its initial state when you press

the  key, press keys  +  +  simultaneously.

The Applications thumbnail displays the status of the programs that are currently running on your computer. The Task column features the list of currently running applications, while the Status column enables you to check whether the software is operating correctly. For instance, as shown below, the Windows Explorer file browser is open; its status displays that this application is "Running". If the Status column displays "Not responding", this means that the relevant software is not functioning correctly. You can close an application by clicking on "End Task".

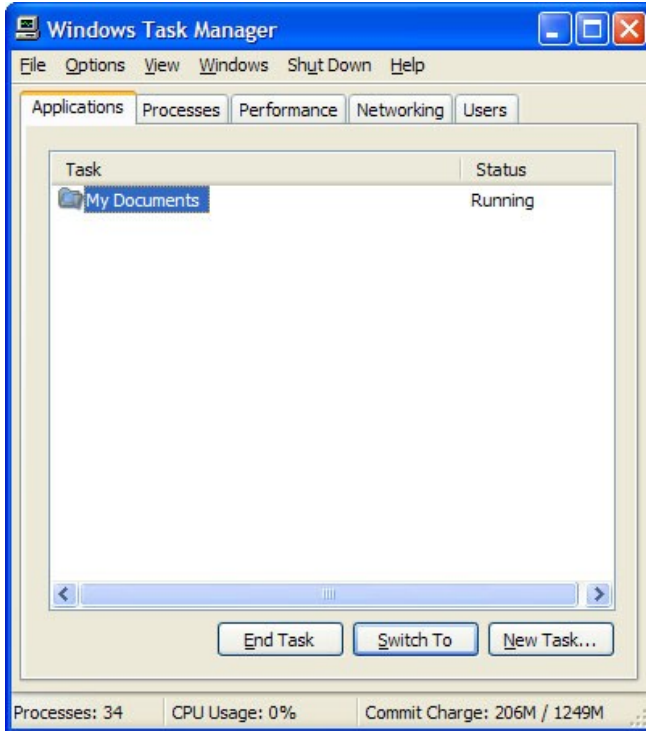

Do not use the forced shutdown or restart procedures when files are open. Irreparable loss of data may occur in this case.

## 3. FIRST STEPS WITH MY ECAFÉ™

### 3.1. Welcome to the eCAFÉ™ galaxy!



When your computer starts up, the Home world is displayed; this page is the starting point of your journey throughout the eCAFÉ™ galaxy. You will have the opportunity to discover many other worlds, each world being dedicated to a specific use: **Work**, **Communications**, **Games**, viewing **Multimedia** contents and configuring or modifying your Netbook's **Settings**.

The icon opens the eCAFÉ™ portal, which allows you to access your online world, use your personal online storage space, view detailed information about the eCAFÉ™ solutions range, discover new applications, obtain hints and tricks, know whether your Netbook is compatible with your equipment or simply discover new uses for your system.

On the left-hand side of the screen, an icon bar enables users to quickly access the various applications and worlds.



You can access the eCAFÉ™'s graphic preferences by clicking on the icon.





Access the Home world or the Windows Desktop



Access the Settings world



Access the eCAFÉ™ portal



Access the Communications world



Access the Personalisation Wizard to customise your ultra-mobile personal computer's settings



Access the Games world



Open the File Browser



Access the Multimedia world



Access the Work world

### 3.2. Connecting an external display

When at home or working at the office, you can connect your Netbook to a larger screen, e.g. to surf the Internet or work on large spreadsheets. To do so, simply connect your eCAFÉ™ to a VGA display using the device's VGA connector.



Switch from the LCD display to an external display

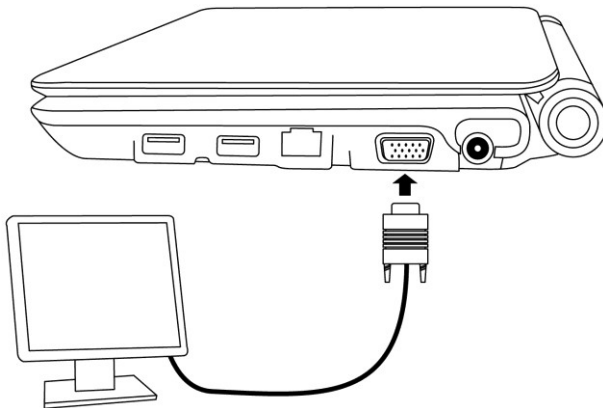

### 3.3. Mastering the touchpad

Some actions are confirmed by a single click (activating a button or accessing a menu, for instance):

Either by pressing the left touchpad button once

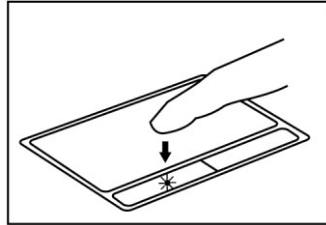

Either by briefly tapping the touchpad

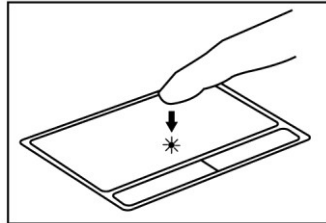

Other actions are confirmed by means of a double-click (opening audio or video contents or a document, for instance):

Either by pressing the left touchpad button twice

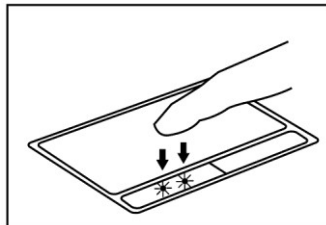

Either by briefly tapping the touchpad twice

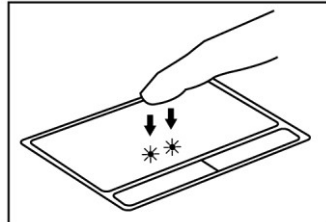

The **right touchpad button** is generally used to access the selected object's properties.



### 3.4. Accessing the online help and tutorials

Many guides are available on your eCAFÉ™. To access them, click on the Start menu in the lower left-hand section of the screen, then select the application Windows Help and Support.

### 3.5. Extensive contents to take you further

Users wishing to make the most of their eCAFÉ™ will enjoy the wide array of tools included with the Microsoft® Windows® XP operating system.

*Loading my files from a removable media (USB key, SD memory card or CD/DVD):*

- Connect the removable media. The eCAFÉ™ automatically detects the newly connected device and displays the USB symbol in the status bar, in the lower right-hand section of the screen.
- In the Windows Explorer file browser that automatically appears onscreen, click on your removable media's name (it is now displayed in the left-hand pane).
- Select the files that you wish to load (hold the  key down to select several consecutive files, or hold the  key down to select several non-consecutive files).
- In the Edit menu, select Copy.
- In the File Browser, select a destination location for your files.
- In the Edit menu, select Paste.

*Loading my files via a network connection:*

To load files via a network connection, you must connect your eCAFÉ™ to a network using the Ethernet port or a WiFi connection. You can then access the relevant files via the network.

*Loading my photos from a digital camera:*

- Connect a digital camera to one of the three available USB ports.
- Turn your digital camera on. The eCAFÉ™ automatically detects the newly connected device.
- In the Windows Explorer file browser, click on the name of the memory card matching the digital camera displayed in the left-hand pane.
- Then, select the pictures that you want to copy to your eCAFÉ™'s hard disk drive.

#### Status bar and Notification area

The status bar displays the thumbnails of the currently launched applications, while the notification area (located in the lower right-hand section of the screen) displays the battery's charge level and status, the network connection (WiFi or Ethernet), the CPU usage level and a clock.



## 3.6. Connecting to the Internet

### 3.6.1. eCAFÉ™ Connect and the WiFi feature



Launch eCAFÉ™ Connect from the Communications world

**Option no. 1**



Launch eCAFÉ™ Connect from the status bar

**Option no. 2**





Activate/Deactivate the WiFi feature

eCAFÉ™ Connect is a software application developed by Hercules, which enables you to manage your network connections (both Ethernet and WiFi) in a user-friendly, intuitive way. It is the essential complement of the eCAFÉ™'s built-in WiFi board.

To access eCAFÉ™ Connect (option no. 2):

- Right-click on the Hercules eCAFÉ™ Connect icon located in the status bar using the right touchpad button.

- Select **Network connection status**.

- Activate your eCAFÉ™'s WiFi feature by pressing on keys  and . The computer's WiFi indicator should light up.



This feature is not activated when the system starts up, and the WiFi indicator is off.

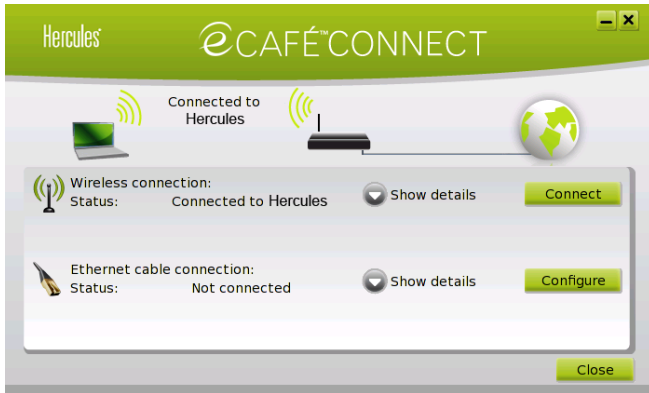

We shall now proceed to locate the available WiFi networks and proceed to set up a wireless connection to the Internet.

- Click on the **Configure** button facing the wireless connection.

The eCAFÉ™ Connect WiFi Station application proceeds to automatically locate the available networks, and displays the detected networks.

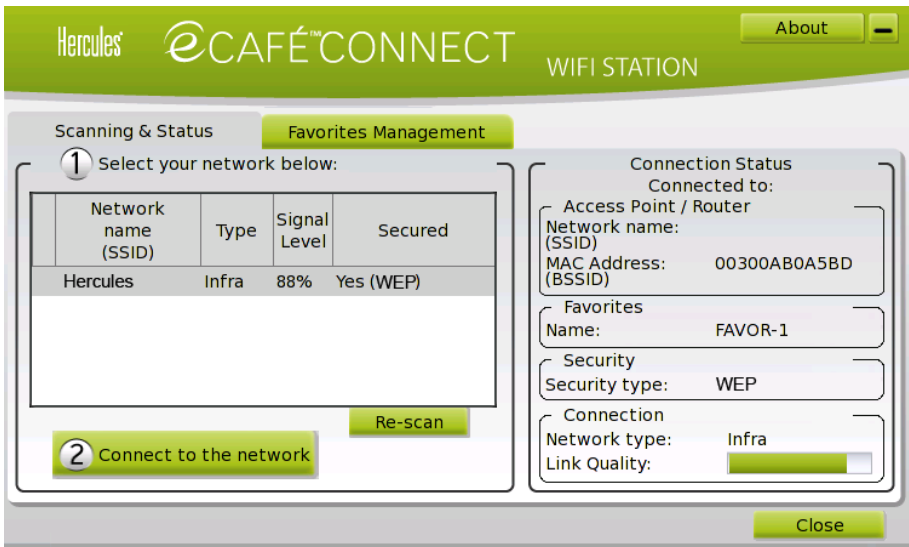

Once your eCAFÉ™ is connected to the internet, the application might prompt you to download the latest eCAFÉ™ Connect version which will provide you with an optimized version of the software.

- In the **Manual connection** window, select the required network.
- Click on the **Connect** button.

*A Connection Wizard launches, and asks you if you wish to add this network to your favourites.*

- If you wish to do so, you can add the network to your favourites by checking the **Yes** box; you will then be requested to provide a name for the network.

*A few seconds later, a green icon displays facing the network, indicating that you are connected.*

If you want your computer to automatically connect to a specific network when the WiFi feature is activated, add the network to your Favourites list and select the **Connect automatically** option.



If the connection to the chosen network fails in the **Infrastructure mode**, check your router's security settings (safety key, MAC address filtering etc.).

**Note:**

The **Infrastructure mode** is a communication mode that consists in creating a network connecting several computers equipped with a WiFi feature via a wireless access point such as an Internet box, a modem/router or a router connected to a modem. The **Infrastructure mode** is ideal for exchanging data or playing games over a network, but also for sharing an Internet connection and/or a printer between several computers.

The **Ad hoc mode** is a mode that enables several computers equipped with a WiFi feature to communicate directly with each other. This mode is also called "Peer to Peer".

A **MAC address** is a unique address created by the router's vendor; it serves to identify this device on a network. The MAC address is comprised of the organisation's (i.e. the vendor's) identifier, followed by the device's unique identifier.

**Connecting manually to a secure network (a safety key type appears in the Secure field):**

- In the **Manual connection** window, select the required network.
- Click on **Connect**.
- Enter the safety key when asked by the WiFi Station application.
- If you wish to do so, you can add the network to your favourites by checking the **Yes** box; you will then be requested to provide a name for the network.



If you wish to connect to a secure network, you must have access to the network's safety key. Before the connection can be made, the eCAFÉ™ Connect WiFi Station application will ask you to provide this key (a message will help you identify the required key type).

**Connecting manually to a hidden network (the Network name (SSID) field is empty):**

If, among the located networks, one or more networks do not have a name (i.e. the Network name (SSID) field is empty), this means that the network is not broadcasting its name. To connect to this network, select it, then:

- In the **Manual connection** window, select the required network.
- Enter the network's name (SSID) in the window that displays.
- If this network is secure, enter the used safety key.
- If you wish to do so, you can add the network to your favourites by checking the **Yes** box; you will then be requested to provide a name for the network.







For enhanced navigation comfort, you can either use your Internet browser's zoom



feature or press key F11 to switch from a fullscreen display to a windowed display.

### For more information about the connection status:

The eCAFÉ™ Connect icon appears in the notification area. It provides updated information about the connection's status:

	<b>Internet connection:</b> an Ethernet or WiFi peripheral is active and physically connected; Internet access is available.	Your Internet connection is perfectly operational.
	<b>Local area connection:</b> an Ethernet or WiFi peripheral is active and physically connected; no Internet access is available.	You are connected to a modem, a router or an Internet box or to a corporate network; however, this device or network is not connected to the Internet. Please check the Internet connection settings on your local area network or your modem.
	<b>Connection problem:</b> an Ethernet or WiFi peripheral is active and physically connected; no Internet access is available.	Please check your network connection settings (IP address, subnet mask etc.) on your local area network or your modem. If necessary, contact your router's or modem/router's vendor.
	<b>No connection:</b> an Ethernet or WiFi device is active but is not connected physically.	Connect your eCAFÉ™ to a local area network via the WiFi connection (please refer to the previous section) or via the Ethernet port.
	<b>No peripheral:</b> no Ethernet and/or WiFi peripheral have been activated.	Activate your peripheral: to activate your WiFi peripheral, simultaneously press on keys [Fn] and [F1] on your ultra-mobile personal computer's keyboard.

**If your computer uses the Microsoft Zero Config utility to establish a connection to the WiFi network:**

### *3.6.2. Using the Microsoft Zero Config utility to establish a connection to the WiFi network*

1. In the windows system tray, click the  **Wireless Network Connection** icon.
2. In the list of available networks that appears, click the desired network, then click the **Connect** button.



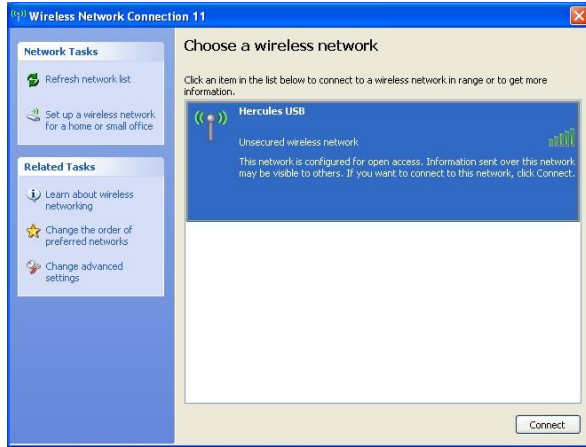

By default, your wireless network is not secure; the connection will be automatically established and saved so as to connect automatically each time you restart your computer.



If the wireless network is secure, you will be prompted to enter a password (or security key).

3. You can now verify that the connection to the WiFi network is working properly by launching your Internet browser.

### 3.6.3. Connecting to the Internet via a DSL network or a Local Area Network (LAN)

To connect to the Internet via a DSL connection or a local area network, simply connect your eCAFÉ™ to the DSL modem or local area network's Ethernet port.

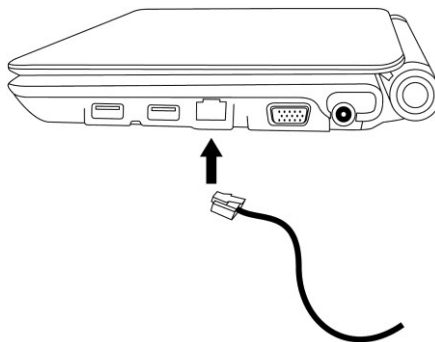

An information window displays in your eCAFÉ™'s status bar, enabling you to view the network connection. Then, launch your Internet browser.



For enhanced navigation comfort, you can either use your Internet browser's zoom  feature or press key F11 to switch from a fullscreen display to a windowed display.

### For more information about the connection's status:

The eCAFÉ™ Connect icon appears in the notification area. It provides updated information about the connection's status:



**Internet connection:** an Ethernet or WiFi peripheral is active and physically connected; Internet access is available.

Your Internet connection is perfectly operational.

**Local area connection:** an Ethernet or WiFi peripheral is active and physically connected; no Internet access is available.

You are connected to a modem, a router or an Internet box or to a corporate network; however, this device or network is not connected to the Internet. Please check the Internet connection settings on your local area network or your modem.

**Connection problem:** an Ethernet or WiFi peripheral is active and physically connected; no Internet access is available.

Please check your network connection settings (IP address, subnet mask etc.) on your local area network or your modem. If necessary, contact your router's or modem/router's vendor.

**No connection:** an Ethernet or WiFi device is active but is not connected physically.

Connect your eCAFÉ™ to a local area network via the WiFi connection (please refer to the previous section) or via the Ethernet port.

**No peripheral:** no Ethernet and/or WiFi peripheral have been activated.

Activate your peripheral: to activate your WiFi peripheral, simultaneously press on keys [Fn] and [F1] on your ultra-mobile personal computer's keyboard.

## 3.7. Sending and receiving emails

Whether at home or "on the road", it is often useful to be able to access your email account. Once you are connected to the Internet, you can send and receive emails and attachments with **Windows Live™**



**Mail**, which is available in the Communications world



Please refer to the connection information provided by your Internet Services Provider. You will need this information to configure your email account correctly.

The Email Configuration Wizard launches when you first run the application, in order to help you setup your email account.

### 3.8. Chatting with friends

Instant messaging has become an essential communication tool, which allows you to chat in real time with your friends or colleagues (i.e. your **Contacts**). This is why the eCAFÉ™ features **Windows Live™ Messenger™**



**Messenger™**, an instant messaging service available in the Communications world. The **Windows Live™ Messenger™** configuration wizard launches when you first run the instant messaging application, in order to help you setup your instant messaging account.

**Note:** Your instant messaging account remains accessible via the icon located in the notification area, in the lower right-hand section of the screen, until you definitely close **Windows Live™ Messenger™**.

### 3.9. Using the webcam



Starting the webcam

Explore another side of digital communications thanks to the webcam built into your eCAFÉ™: Take pictures, Record video clips easily with the super user-friendly Hercules Webcam Station Evolution SE. On your eCAFÉ™'s hard disk drive, you will find a user's manual describing the software's features:

- Photo capture in 3 modes: simple, continuous, timer
- One-click video capture
- Automatic conversion and resizing of captures for email attachments



### 3.10. Work

Included on your eCAFÉ™, the OpenOffice.org® suite is a user-friendly office application suite that allows you to create documents (e.g. letters, reports and more), simple or complex spreadsheets and elaborate slideshows.

Regardless of the OpenOffice.org® application that you are using (**Spreadsheet, Word Processor or Slideshow**), you can create a **new** document of any type (in this case, the OpenOffice.org® suite automatically switches to the relevant application) or **open** an existing document. All your Microsoft® Office documents can be opened and edited using the OpenOffice.org® suite.

 For further information regarding the selected application, please refer to the application's online help file; you can access this content by pressing on F1.

#### 3.10.1. *Creating, editing and saving a document using OpenOffice.org Writer (Word processor)*

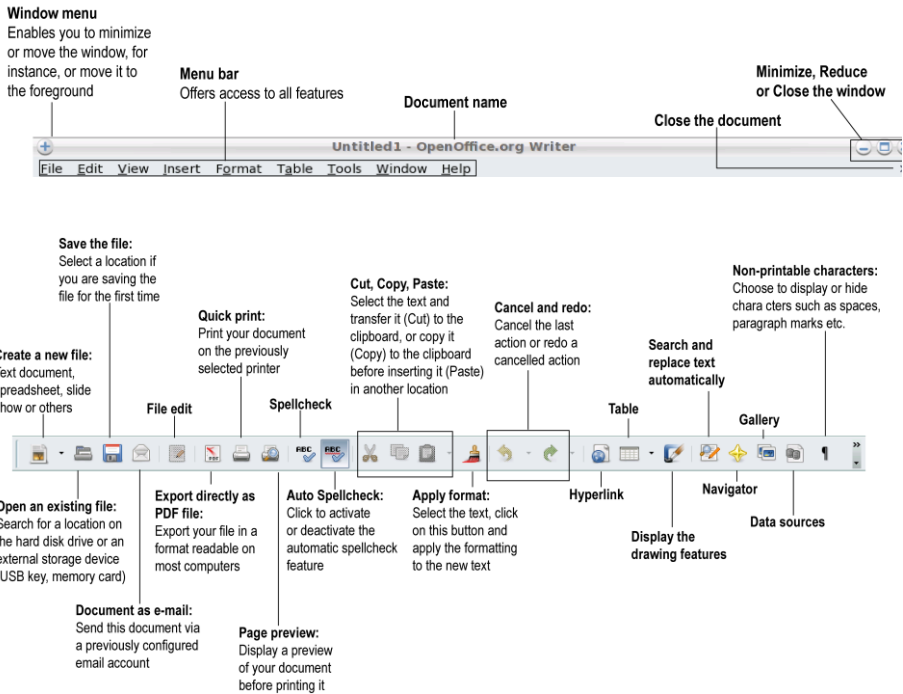

**Window menu**  
Enables you to minimize or move the window, for instance, or move it to the foreground

**Menu bar**  
Offers access to all features

**Document name**  
Untitled1 - OpenOffice.org Writer

**Close the document**  
Minimize, Reduce or Close the window

**Save the file:**  
Select a location if you are saving the file for the first time

**Quick print:**  
Print your document on the previously selected printer

**File edit**

**Spellcheck**

**Cut, Copy, Paste:**  
Select the text and transfer it (Cut) to the clipboard, or copy it (Copy) to the clipboard before inserting it (Paste) in another location

**Cancel and redo:**  
Cancel the last action or redo a cancelled action

**Non-printable characters:**  
Choose to display or hide characters such as spaces, paragraph marks etc.

**Create a new file:**  
Text document, spreadsheet, slide show or others

**Open an existing file:**  
Search for a location on the hard disk drive or an external storage device (USB key, memory card)

**Export directly as PDF file:**  
Export your file in a format readable on most computers

**Auto Spellcheck:**  
Click to activate or deactivate the automatic spellcheck feature

**Apply format:**  
Select the text, click on this button and apply the formatting to the new text

**Hyperlink**

**Search and replace text automatically**

**Table**

**Navigator**

**Gallery**

**Data sources**

**Display the drawing features**

**Document as e-mail:**  
Send this document via a previously configured email account

**Page preview:**  
Display a preview of your document before printing it

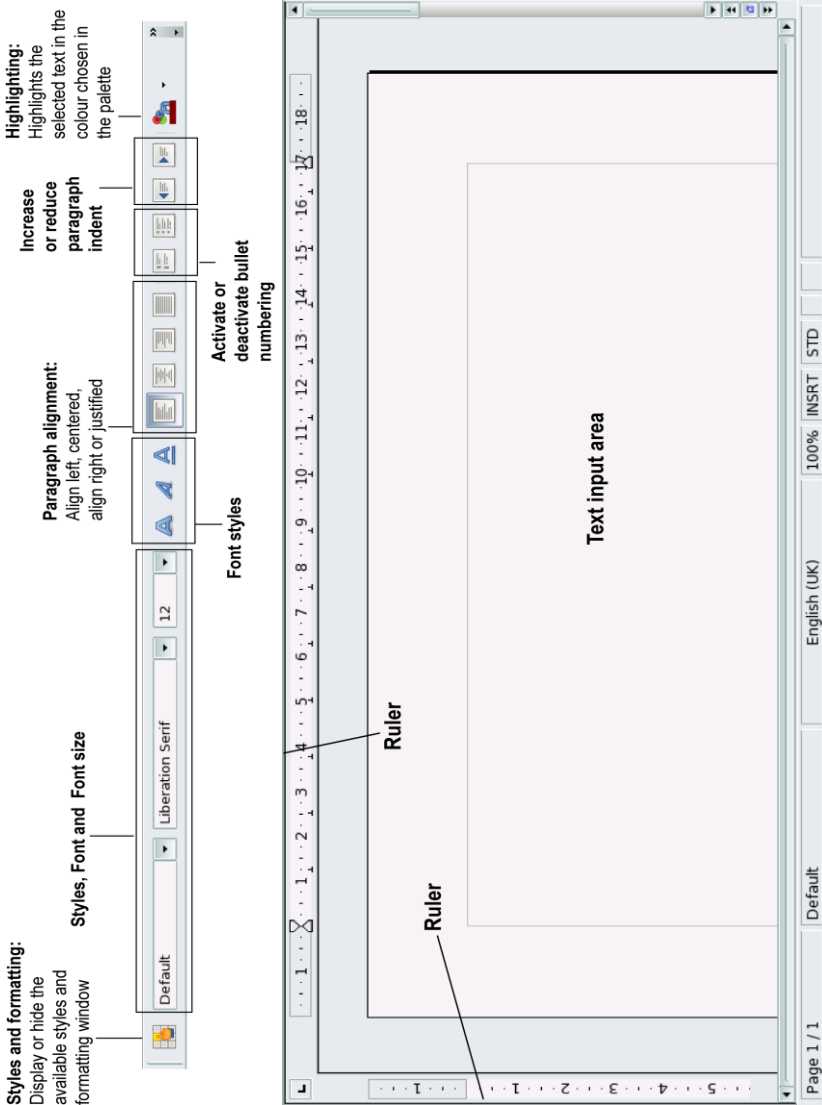

### 3.10.2. Creating, editing and saving a spreadsheet using OpenOffice.org Calc (Spreadsheet)

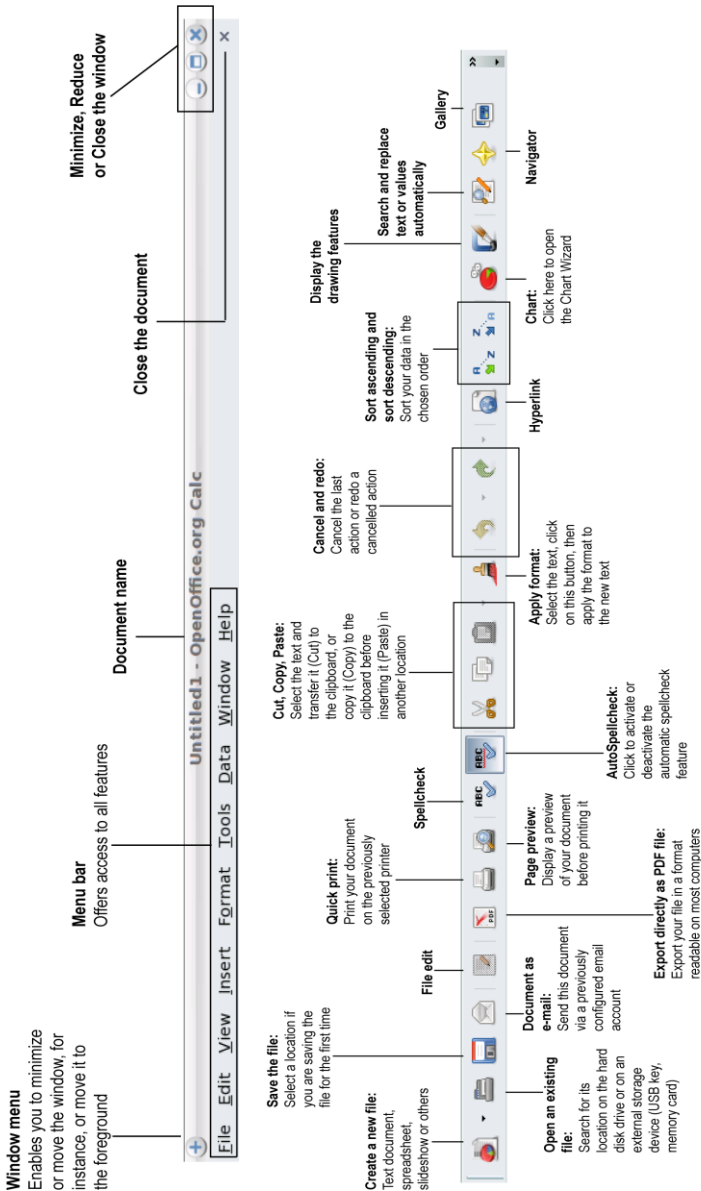

**Styles and formatting:**  
Display or hide the available styles and formatting windows

**Styles, Font and Font size**  
Liberation Sans 10

**Font styles**

**Paragraph alignment:**  
Align left, centered, align right or justified

**Number format:**  
Currency, Percent  
Select one of these icons to choose a number format for the cells

**Reduce or increase indent**  
Select one of these icons to choose a number format for the cells

**Number format:**  
Add or remove a decimal place

**Borders:**  
Click on the arrow to choose a border, then click on the required cell(s)

**Merge cells:**  
Select several cells and click here to merge them into one cell

**Display/Hide the border of the cells**

**Function Wizard**  
Helps you enter formulas

**Current cell's name box**  
A1

**Formula bar**  
=

	A	B	C	D	E	F	G	H	I
1									
2			Sum						
3			Inserts the Sum function in the formula						
4									
5									
6									
7									
8									
9									
10									
11									
12									
13									
14									
15									
16									
17									
18									
19									

**Active spreadsheet**

Sheet1 / Sheet2 / Sheet3 | 100% | STD | Sum=0

### 3.10.3. Creating, editing and saving a slideshow using OpenOffice.org Impress (Slideshow)

We shall now create a simple slideshow in 5 steps, using the **Slideshow Wizard** that launches when you click on the Slideshows icon located on your desktop.

1. Create a slideshow **from a template**. Choose one of the available templates, then click on **Next**.

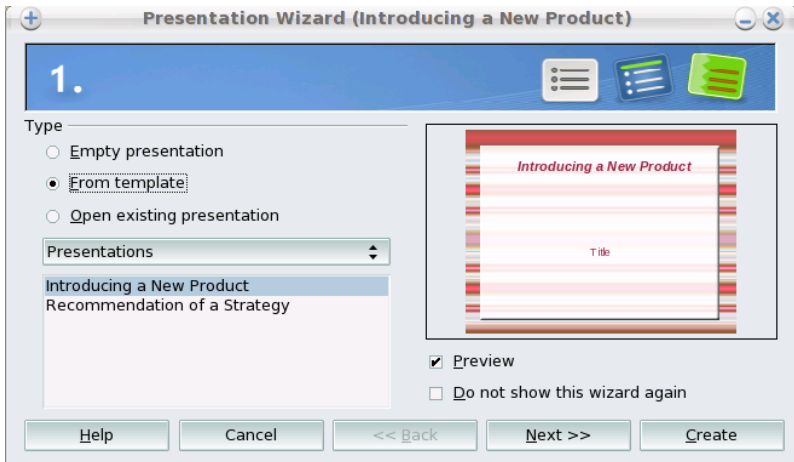

2. Choose your **background**. Click on **Next**.

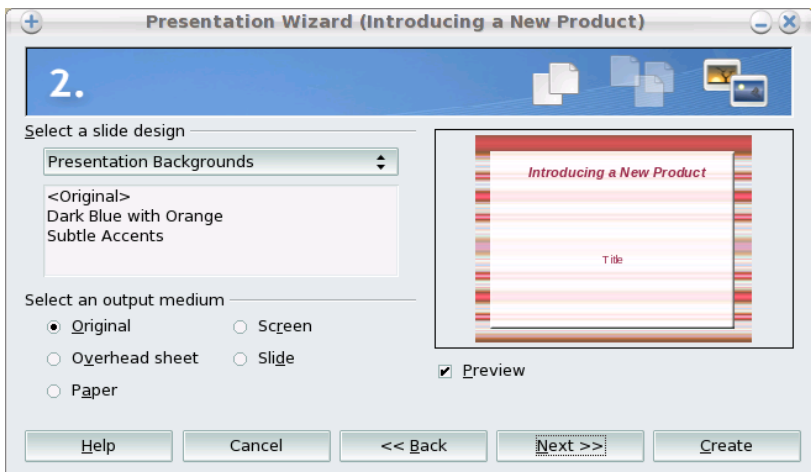



3. Select a Slide **transition** and the speed of the transition between two slides. Click on **Next**.

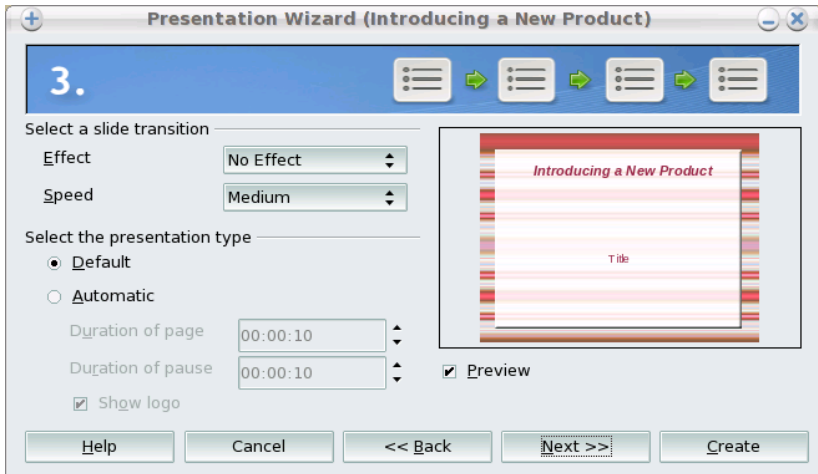

4. Enter the **information** that you wish to include in your slideshow. You will be able to amend this information after. Click on **Next**.

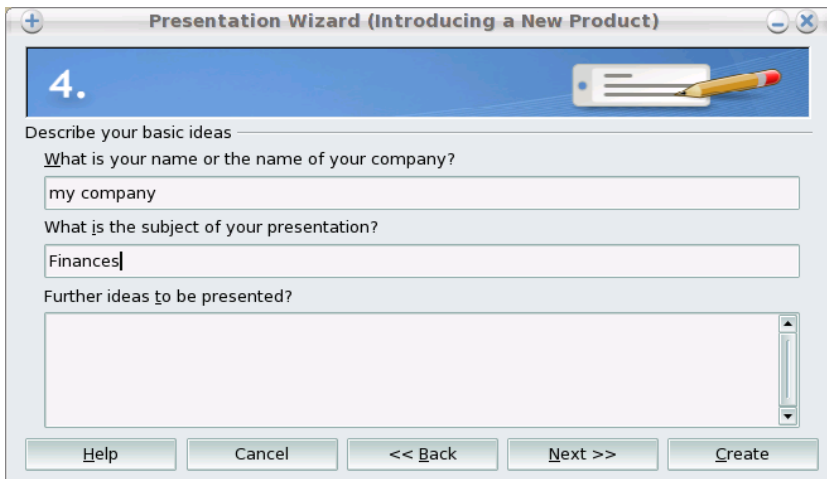

5. Select the pages that will comprise the structure of your slideshow. Click on **Create**.

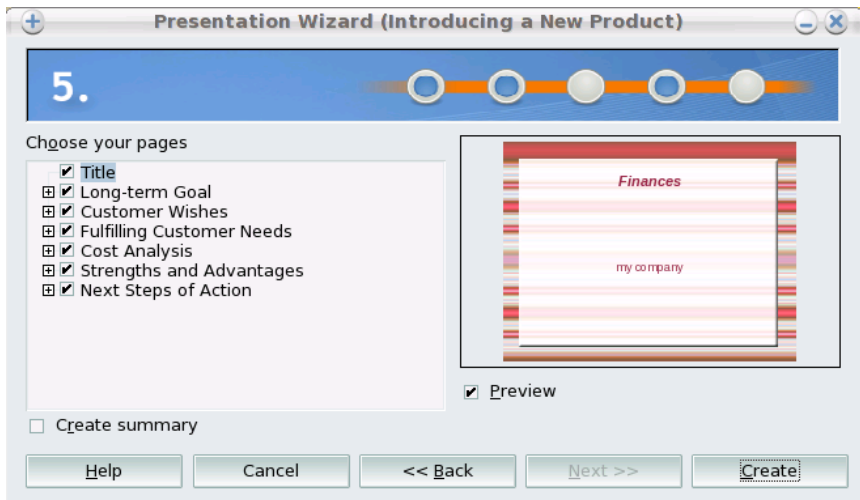

Your slideshow is now displayed in OpenOffice.org Impress. You can now finalise your presentation by creating objects, connectors, etc.

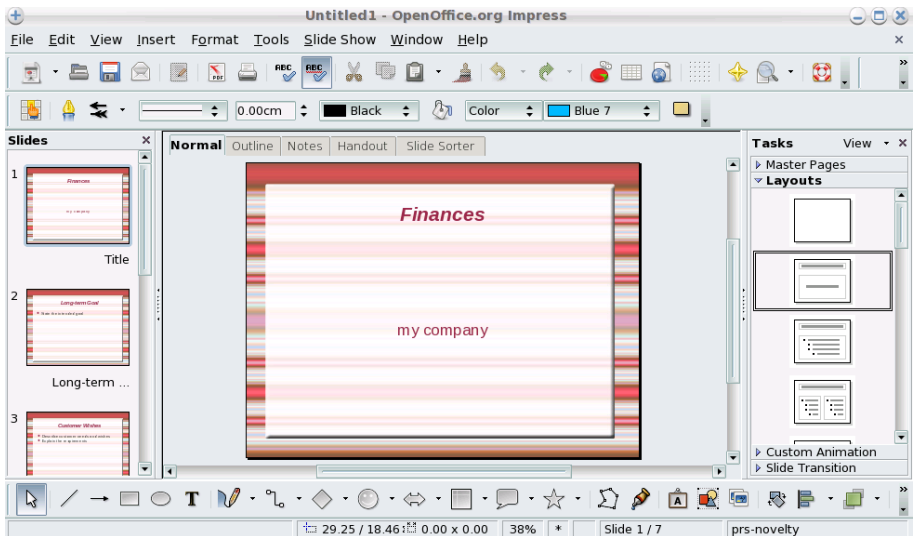

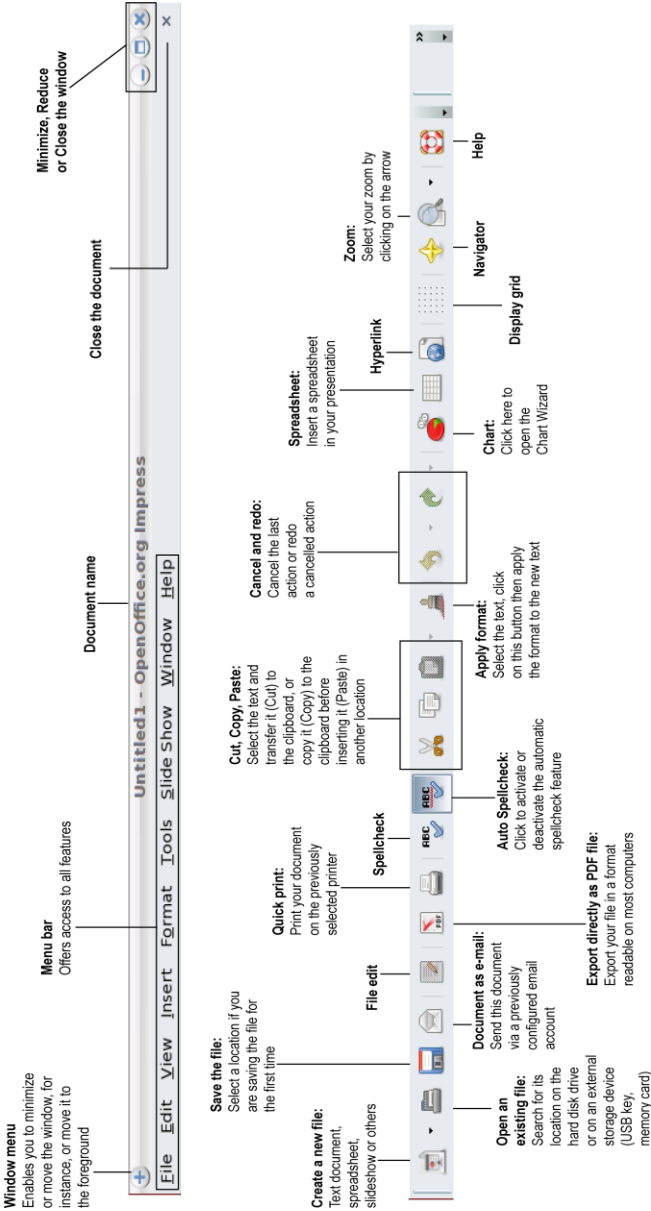

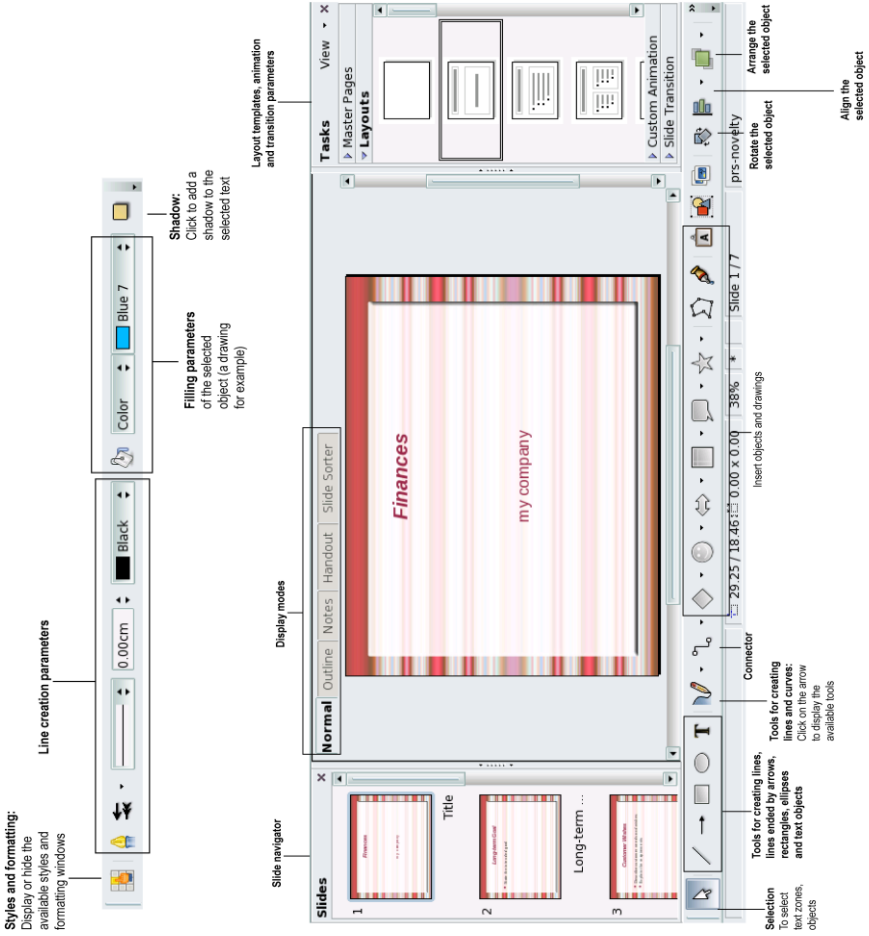



### 3.11. Saving data to a removable media (USB key, memory card)

In this section, we will explain how to back up your data on various media. You can also connect to the website [Hwww.ecafe.hercules.com](http://www.ecafe.hercules.com) In the section dedicated to the eCAFÉ™, you will find all the information you require to back up your data.



We also recommend that you frequently back up any personal or sensitive data that you may have stored on your Netbook.

- Connect the removable media. eCAFÉ™ automatically detects the newly connected device.
- In the Windows Explorer File Browser, select the files and/or directories that you wish to backup (hold the  key down to select several consecutive files, or hold the  key down to select several non-consecutive files).
- In the **Edit** menu, select **Copy**.
- In the Windows Explorer File Browser, click on your removable media's name (which appears in the left-hand pane).
- Choose the destination location for the files.
- In the **Edit** menu, select **Paste**. Your files and/or folders will be copied to your removable media.
- Wait for the copy to end, then remove your removable media: click on the  icon (located in the lower right-hand side of the screen) and select "Remove media".

### 3.12. Protection software for your eCAFÉ™

If you often connect to the Internet and use your eCAFÉ™ to download games, programs and music, your system is exposed to the risk of malicious applications, such as viruses. These applications are able to spread to other systems via the emails you send to your friends, and can alter your system's settings and corrupt it.

Anti-virus applications designed by specialised software publishers may help reinforce your eCAFÉ™'s protection.

## INDEX

- Battery, 13
- Display modes
  - Fullscreen, 25, 26
  - Windowed, 25, 26
- eCAFÉ™, 3, 4, 7, 10, 28, 29, 39
- eCAFÉ™ portal, 17
- eCAFÉ™Connect, 24, 25, 26
- File Browser, 18
- Help, 29
- Home, 7, 17, 18
- Memory cards, 4
  - MMC, 4
  - SD, 4
  - SD HC, 4
- Multifunction keyboard, 25, 26
- Netbook, 3
- OpenOffice.org Calc (Spreadsheet), 32
- OpenOffice.org Impress (Slideshow), 34
- OpenOffice.org Writer (Word processor), 29
- OpenOffice.org™, 29
- Personalisation Wizard, 18
- Pictures, 28
- Removable media, 39
- Safety key, 23, 24, 25
- Video, 28
- Webcam, 28
- WiFi, 3
- WiFi connection, 25, 26
- WiFi feature, 24
- World
  - Communications, 17, 18
  - Games, 17, 18
  - Multimedia, 17, 18
  - Settings, 17, 18
  - Work, 17, 18

## TECHNICAL SUPPORT

If you have trouble using your device or one of its components, please connect to the <http://ts.hercules.com/> website and select your language. Here, you will be able to access different services (Frequently Asked Questions (FAQs), the latest versions of all available drivers and software) that may help you solve your problem. If this fails to solve the problem, please get in touch with Hercules' Technical Support.

### Via email:

To reach our Technical Support via email, you must first register online on the <http://ts.hercules.com/> website. The information that you provide will help our technicians solve your problem as swiftly as possible.

Click on **Product Registration** and follow the instructions displayed onscreen.

If you have already registered your product, please enter your credentials in the **Username** and **Password** fields, then click on **Login**.

By telephone (if you do not have Internet access):

**United Kingdom**

**08450800942**  
Charges at local rate

Monday to Friday from Noon to 4pm and 5pm to 10pm  
Saturday from 9am to Noon and 1pm to 7pm  
Sunday from 9am to Noon and 1pm to 4pm

Connect to the Hercules website ([www.ecafe.hercules.com](http://www.ecafe.hercules.com)) to view the Frequently Asked Questions (FAQs) relevant to your product, discover your eCAFÉ™'s features and download the latest updates. You can also discover the extensive range of eCAFÉ™ products and download information about the forthcoming releases.

## WARRANTY INFORMATION

Guillemot Corporation S.A. ("Guillemot") guarantees consumers worldwide that this Hercules product is free from material and manufacturing defects for a period of one (1) year beginning on the original date of purchase. Should the product seem defective during the period covered by the warranty, please contact our Technical Support immediately for further information on how to proceed. After contacting our Technical Support, if it appears necessary to return the product to us, please return the product and its accessories in the original packaging, well packaged and protected, according to the instructions provided by our Technical Support.

According to the terms of this warranty, following our Technical Support's decision, the defective product may be repaired or replaced. When authorised by applicable law, any liability incurred by Guillemot and its subsidiaries (including consequential damages) will be limited to repair or replacement of the product manufactured by Hercules. The consumer's statutory rights on account of applicable law on the sale of consumer goods are not affected in any way by this warranty.

This warranty will not apply:

(1) If the product has been modified, opened, altered in any way or damaged by inappropriate or abusive use, negligence, an accident or normal wear; (2) If the product has been used or stored in abnormal conditions (e.g. exposition to adverse weather conditions, to direct sunlight, to water or to sand); (3) For any other reason not relating to a material or manufacturing defect; (4) In the event of non-observance of the instructions provided in the User Manual or by our Technical Support; (5) To any software not edited by Guillemot, said software being covered by a specific warranty granted by the software's editor; (6) If the warranty seals have been removed or altered in any way; (7) For damages to or the loss of programs, data or storage media, or for the costs arising from the retrieval of said data; (8) For damages to or the loss of programs or personal data occurring after repair or replacement of the product; (9) For damages caused by the installation of third-party software or by computer viruses.

Guillemot shall in no event be held responsible for any damage to or loss of personal data, programs, software or removable storage media. Before returning this program to Technical Support, please create a backup of any personal and/or sensitive data. In addition, in order to preserve your data's confidentiality, Guillemot recommends you delete any data from your device after backing it up. Guillemot shall in no event be held responsible for reinstalling or retrieving personal data or programs other than those installed at the time of the product's commercialisation.

The warranty applies to your product's display if the display features at least 5 defective pixels (i.e. bright spots or dark spots, a bright spot being a white pixel permanently displayed on the screen, and a dark spot being a pixel that does not display on the screen.)

In the event where the product is returned to our Technical Support and the warranty cannot be applied owing to the presence of one or several of the exclusion conditions stated above, the incurred shipping and processing costs will be charged to the consumer.

### Registered trademarks

Hercules® and eCAFÉ™ are registered trademarks of Guillemot Corporation S.A. OpenOffice.org® is a trademark of Team OpenOffice.org e.V. Microsoft®, Windows®, Windows Live®, Microsoft® Windows® XP, MSN®, Internet Explorer® and the Windows flag are trademarks or registered trademarks of Microsoft Corporation in the United States and/or in other countries. Wi-Fi is a registered trademark of the Wi-Fi Alliance. All other registered trademarks and brand names are hereby acknowledged and are the property of their respective owners. Illustrations not binding. Contents, designs and specifications are liable to change without prior notice and may vary according to countries.

Made in China

### Statement of Compliance with EU Regulations

Guillemot Corporation S.A. hereby declares that the device **UMPC EC-900B-H120G/VW** complies with the with the main requirements and other relevant clauses of Directive RTTE 1999/5/CE, of Directive CEM 2004/108/CE and with the standards relating to electrical security (IEC 60950, 2001 Edition / EN 60950-1, 2001 Edition / NF EN 60950, Amendment A11-2004). The compliance statement can be viewed on the following website:

[ftp://ftp.hercules.com/EC-900B/H120G-VW/DoC-fra\\_UMPC\\_EC-900B-H120G.pdf](ftp://ftp.hercules.com/EC-900B/H120G-VW/DoC-fra_UMPC_EC-900B-H120G.pdf)



### Copyright

© 2009 Guillemot Corporation S.A. All rights reserved.

No part of this manual may be copied, summarised, issued, posted, stored in a search engine or translated in any language or computer language, for any purpose or by any means that may be, whether electronic, mechanical, magnetic, manual, by means of photocopies, recordings or others, without the express authorisation in writing of Guillemot Corporation S.A.

## End User License Agreement

**IMPORTANT:** Please read the following End User License Agreement before using the eCAFÉ™ device. The term "Software" refers to all executable programs, managers, libraries, data files and to any documentation relating to the programs, as well as the complete operating system included in the eCAFÉ™ product. The Software is licensed, and not sold, to the User, exclusively for use complying with the terms of this License Agreement. The Software is comprised of free software sub-applications provided by the Free Software Foundation (applications, product administration programs, etc.), which are sub-licensed by Guillemot Corporation S.A. under the conditions described in point 5 above. You hereby accept and agree to abide by the Terms & Conditions of this License Agreement. If you disagree with the Terms & Conditions of this License Agreement, please do not use the Software.

The Software is protected by international copyright laws and agreements, as well as other international laws and agreements relating to intellectual property.

The Software (excluding the software sub-applications) remains the property of Guillemot Corporation S.A. All rights reserved. Guillemot Corporation S.A. grants only a limited and non-exclusive right to use the Software.

**Guillemot Corporation S.A. reserves the right to cancel this License Agreement in the event of failure to abide by its Terms & Conditions.**

### License granted:

1. The license is granted to the original Buyer alone. Guillemot Corporation S.A. remains the sole owner and holder of the Software (excluding the software sub-applications), and reserves all rights that are not expressly granted by this License Agreement. The User is not allowed to sub-license the rights granted by this License Agreement. The User is allowed to transfer this License, provided that the original Buyer retains no part of the Software and that the Transferee reads and accepts the Terms & Conditions of this License Agreement.
2. The Buyer may only use the software on one computer at a time. The machine-readable part of the Software may be copied to another computer, provided that the Software is deleted from the first computer and that it is impossible to use the Software on several computers at the same time.
3. The Buyer hereby acknowledges and accepts the copyright belonging to Guillemot Corporation S.A. The copyright shall in no event be removed from the Software, nor from any documentation, whether printed or electronic, provided with the Software.
4. The License grants the User the right to perform one (1) copy of the machine-readable part of the Software for archival purposes, provided that the User also copies Software's copyright.
5. The free software sub-applications provided by the Free Software Foundation and sublicensed by Guillemot Corporation S.A. are subject to the Terms & Conditions of the General Public License (GPL), which is available at the following address: <http://www.gnu.org/licenses/>. The source codes of these software sub-applications are available at the following address: <http://www.hercules.com>. Some of these software sub-applications have been modified by Guillemot Corporation S.A. (the list of these software sub-applications is available on the following website: <http://www.hercules.com/fr>). <http://www.hercules.com> ).
6. Except within the limits expressly allowed by this License Agreement, the Buyer may not agree or allow any third party to agree to: grant a sublicense; provide or divulge the Software to other third parties; allow use of the Software on several computers at a time; perform alterations or copies of any kind; reverse engineer, decompile or modify the Software in any way or attempt to obtain information relating to the Software that is not accessible to the User; perform copies or translations of the User Manual.

### Warranty limitation:

The Software is provided "as is", with no guarantee whatsoever from Guillemot Corporation S.A. regarding its use and/or performance. Guillemot Corporation S.A. does not guarantee that the operation of the Software will be free from interruptions or errors. The use or the performance of the Software remain under the Buyer's entire responsibility, and Guillemot Corporation S.A. can provide no guarantee of any kind with regard to the performance and results obtained by the Buyer while using the Software. No guarantee of any kind, whether explicit or implied, is offered by Guillemot Corporation S.A. with regard to the non-violation of third party rights, the merchantability or the adequacy of the Software to a specific use.

In no event shall Guillemot Corporation S.A.'s liability be engaged in the event of damages of any kind arising from the use or the incapacity to use the Software.

### Applicable law:

The Terms & Conditions of this License Agreement are subject to French Law.

### ENVIRONMENTAL CARE RECOMMENDATIONS



At the end of its useful life, this product should not be discarded with standard household refuse but should be given to a collection point for waste from electric and electronic devices, where it shall be recycled.

This is stated by the symbol that appears on the product, the User Manual or the packaging.

According to their specificities, these materials may be recycled. By supporting recycling and other methods of recovering waste from electric and electronic equipment, you help care for the environment.

Please consult with the local authorities, who will refer you to the relevant waste collection point.