

CONTENTS

1. INTRODUCTION	2
1.1. Box contents	2
1.2. Specifications	2
1.3. Overview of the speaker's front face	2
1.4. Overview of the speaker's back face	3
1.5. Safety instructions	3
2. USING THE SPEAKER	4
2.1. Positioning the speaker	4
2.2. Pairing a Bluetooth® device	4
2.3. WAE application	5
2.4. Pairing another Bluetooth® device	7
2.5. Connecting another music source	8
2.6. Recharging the battery	8
3. TROUBLESHOOTING	9
4. TECHNICAL SUPPORT	10
5. WARRANTY	11
6. ENVIRONMENTAL CERTIFICATIONS AND RECOMMENDATIONS	11

1. INTRODUCTION

We thank you for your purchase of the Hercules WAE wireless speaker. It enables you to listen to audio tracks stored on your iOS device or any other Bluetooth® device, and to take your music with you anywhere.

1.1. Box contents

- 1 Hercules wireless speaker
- 1 power supply
- User manual

1.2. Specifications

Maximum output power	25 W peak power
Frequency response	50 Hz – 20 kHz
Transmission technology	Bluetooth® 3.0 et AD2P
Dimensions	249 mm (H) X 236 mm (W) x 171 mm (D)
Battery life	20 hours at 73 dB SPL @ 1 m
Features	<ul style="list-style-type: none"> - 1 auxiliary input (3.5 mm mini-jack format) - 1 On/Off button - 2 volume buttons - 1 Bluetooth® pairing button - 1 power supply connector
Battery	Rechargeable lithium polymer battery
Power supply	AC/DC 5 V - 2 A

1.3. Overview of the speaker's front face

The speaker features the following buttons and indicators on its front face:

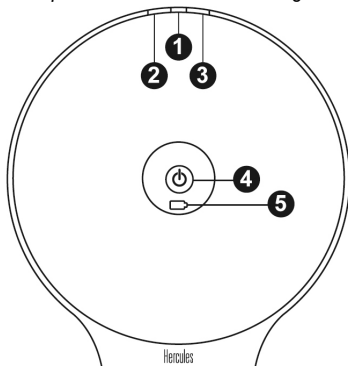

- (1) Bluetooth® pairing indicator light:
 - Flashes when the speaker isn't connected to a device
 - Lights up when the speaker is connected to a device
 - Flashes quickly when the speaker is in pairing mode
- (2) Volume + button
- (3) Volume – button
- (4) On/Off and connection status indicator
- (5) Battery charge level indicator

1.4. Overview of the speaker's back face

The speaker features the following buttons and connectors on its back face:

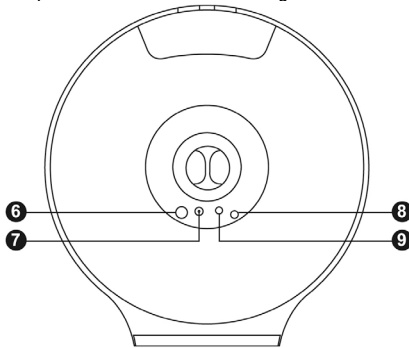

(6) On/Off button

(7) Power supply connector

(8) Bluetooth® pairing button

(9) Auxiliary input connector

1.5. Safety instructions

- Place your speaker on a flat surface, to avoid the risk of the speaker falling.
- Never open up your speaker, as you risk damaging its internal components.
- This speaker is intended for use in a temperate environment.
- To prevent the risk of fire or electrical discharge, keep your speaker away from:
 - rain or humidity, as well as all fluids (water, chemical products or any other liquids),
 - sources of heat such as heaters, stoves or any other heat-producing devices (including amplifiers),
 - direct sunlight.
- Do not expose your speaker to drips or splashes of water.
- Never place any object filled with liquid (a glass, vase...) on your speaker.
- Completely disconnect your speaker if you do not plan on using it for an extended period of time.
- Make sure that the speaker's power plug connected to an electrical outlet remains easily accessible.
- Disconnect the speaker before cleaning. Use a damp cloth and avoid using aerosol cleaners.
- Markings are located on the underside of the speaker.
- The speaker's power plug serves to completely power off the device.
- Replace the speaker's power supply or accessories respecting the specifications of the manufacturer or its authorized representative.
- This product contains no internal pieces which can be repaired by the user. Maintenance must be carried out by the manufacturer or its authorized representative.
- Only use power supply listed in the user manual: GM12-050200-2 Adaptor (ratings: Input: 100/240 VAC, 50/60 Hz, 0.5 A; Output: 5 VDC, 2 A)

WARNING: RISK OF EXPLOSION IF THE BATTERY IS REPLACED BY A BATTERY OF AN INCORRECT TYPE. FOLLOW THE INSTRUCTIONS REGARDING THE DISPOSAL OF BATTERIES.

2. USING THE SPEAKER

2.1. Positioning the speaker

Indoors, the sound quality of the Hercules wireless speaker will vary according to its placement in the room.

If you will be moving the speaker from room to room indoors, please keep the following points in mind:

- To obtain the best possible sound, place the speaker on a shelf, a piece of furniture, a desk or any other flat surface at a height of between 70 and 120 cm from the floor.
- You should ideally position the speaker near a wall, to enhance the bass response. The further you position your speaker from the wall, the lower the bass level will be.
- When in operation, you should always position the speaker on its base: any other position will result in reduced sound quality.
- Do not place the speaker in a narrow, enclosed space, as doing so will result in reduced sound quality.

Outdoors, sound dispersion is greater and will result in reduced sound quality. To mitigate the sound dispersion, place the speaker close to you.

2.2. Pairing a Bluetooth® device

"Pairing" means connecting a smartphone or a Bluetooth® device to your speaker, in order to establish a communication. When two devices are paired, the relevant information is stored in both devices' memory. Once a device has been paired with the speaker, it doesn't need to be paired again.

The speaker can store information about up to 8 devices.

Step 1: Turn the speaker on, if you haven't already done so.



The Bluetooth® pairing indicator light should flash quickly. This means that the speaker is in pairing mode.

If the pairing indicator light doesn't flash, please refer to section 3, further in this manual.

Step 2:

Open your device's Bluetooth® management feature. If using an iOS device, select Settings / General / Bluetooth®.

Activate your device's Bluetooth® feature and wait for the speaker to appear in the list of detected devices.

Locate the **WAE-BTP02** speaker, then tap on it to connect to it.

After a short wait, the connection is set up; the device should now appear as **Connected** in your device's Bluetooth® management feature.



2.3. WAE application

An application is provided with your speaker, and can be downloaded from the App Store. When connecting an iOS device to the speaker for the first time, a notification appears on the screen, inviting you to download the application. If you select **Yes**, you will be redirected to the App Store, where you can download the application.

Please note that an application is also available for Android.

This application offers the following features:

- An audio player enabling you to read all the files in your music library
- An Automix feature offering smooth transitions between tracks
- A webradio feature providing a list of the best radios in your area or elsewhere
- An equalizer feature
- Advanced speaker controls available directly in the application
 - o Control your speaker's volume setting

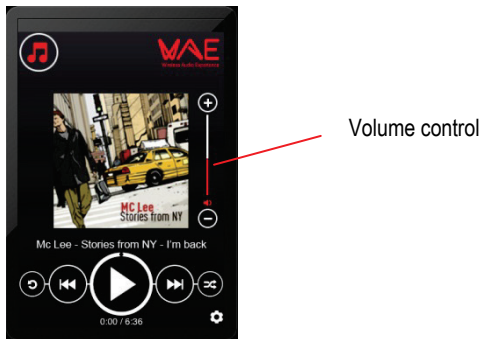

Please note that the speaker's volume setting is independent from your device's volume setting.

- o Select the device that you want to use to play music.

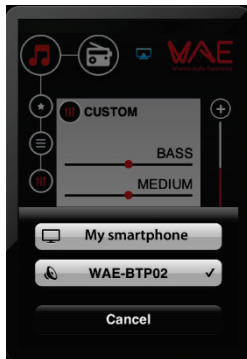

- Select your favourite audio settings.



- Turn your speaker off remotely.



2.4. Pairing another Bluetooth® device

To pair another device:

- 1- Press the Bluetooth® pairing button (8)
- 2- Follow the steps described in section 2.2 to pair your device.

2.5. Connecting another music source

You can connect any other music source to your speaker: for example, an iPod, other type of MP3 player or a mobile phone. To do so:

- 1- Connect one end of a male mini-jack (3.5 mm) cable (not included) to the auxiliary input connector (9), and connect the other end of the cable to the audio output on your music source.
- 2- Set your external music source to the maximum volume, and use the volume buttons on the speaker to adjust the sound level.

Note: To revert to the Bluetooth® mode, simply disconnect the mini-jack cable.

2.6. Recharging the battery

Your speaker is equipped with a rechargeable battery. We strongly recommend that you completely discharge the battery when using the speaker for the first time. To do so, leave the speaker powered on (with the sound active or not) until the speaker completely runs out of power.

To recharge the battery: connect the power supply to its connector on the speaker (7), and then plug the power supply into an electrical outlet.

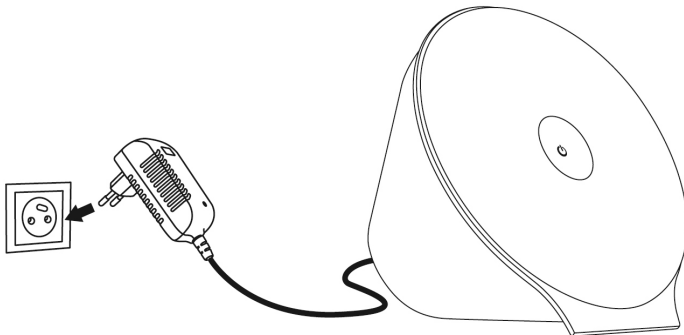

The battery charge level indicator (5) lights up while the battery is charging, and turns off when the battery is fully charged.

3. TROUBLESHOOTING

Problem	Possible solutions
The speaker doesn't power up	<ul style="list-style-type: none"> • The battery may be empty. Connect the speaker to an electrical outlet to charge the battery and power the speaker. • Make sure that the electrical outlet that your speaker is connected to is powered by the mains.
The speaker appears to be connected (the Bluetooth® indicator light (1) is lit), but no sound is heard	<ul style="list-style-type: none"> • Turn off all Bluetooth® devices in the area or deactivate their Bluetooth® feature, then reconnect the device that you want to use for playback. • Turn off the Hercules speaker by moving the ON/OFF switch (6) to OFF, then power it up again by moving the ON/OFF switch (6) to ON.
No sound from a Bluetooth® device can be heard on the speaker	<ul style="list-style-type: none"> • Make sure that your speaker's sound isn't deactivated and that the volume setting isn't on minimum. • Make sure that the Bluetooth® source is active and that the volume setting is high enough. • Your Bluetooth® device may be out of range: move it closer to the device. • Turn off the Hercules speaker by moving the ON/OFF switch (6) to OFF, then power it up again by moving the ON/OFF switch (6) to ON.
No sound from an auxiliary source can be heard on the speaker	<ul style="list-style-type: none"> • Make sure that the device connected to the auxiliary input is powered up and playing a track. • Increase the volume setting on the device connected to the auxiliary input. • Increase the speaker's volume setting.
I can't connect the speaker to a paired Bluetooth® device	<ul style="list-style-type: none"> • If your device requests a password, enter 4 zeros (0000). • Turn off the Hercules speaker by moving the ON/OFF switch (6) to OFF, then power it up again by moving the ON/OFF switch (6) to ON. • Remove the Hercules WAE® speaker from the list of paired devices stored on your Bluetooth® device (for more information, please refer to your speaker's user manual). Then, pair the speaker and the device again.
I can't pair the Hercules speaker with my Bluetooth® device	<ul style="list-style-type: none"> • Press the speaker's Bluetooth® pairing button (8) to activate the pairing mode. • Make sure that the Bluetooth® feature is active on the device that you want to connect. • Your Bluetooth® device may be out of range: move it closer to the device. • Make sure that your Bluetooth® device supports the audio transfer feature (AD2P protocol). • Move your Bluetooth® device and/or the speaker away from any other device liable to cause interference: cordless telephones, microwave ovens, WiFi routers and all other Bluetooth®. • If possible, turn off all other Bluetooth® devices in the area or deactivate their Bluetooth® feature. • Turn off the Hercules speaker by moving the ON/OFF switch (6) to OFF, then power it up again by moving the ON/OFF switch (6) to ON. • Delete the speaker's pairing table. Press and hold the Volume + (2) and Volume - (3) buttons simultaneously for 10 seconds. The indicator light turns off, then starts flashing quickly.
Poor sound quality in auxiliary mode	<ul style="list-style-type: none"> • Lower the volume setting on the auxiliary source. • Make sure that the 3.5 mm mini-jack is correctly inserted in the connector.

Poor sound quality in Bluetooth® mode	<ul style="list-style-type: none"> • Your Bluetooth® device may be out of range: move it closer to the device. • Move your Bluetooth® device and/or the speaker away from any other device liable to cause interference: cordless telephones, microwave ovens, WiFi routers and all other Bluetooth®. • If several applications are running simultaneously on the Bluetooth® device, close any non-essential applications. Running multiple applications simultaneously reduces the internal resources required by audio transmission. • Deactivate the WiFi network. • Cancel the pairing between your Bluetooth® device and speaker, then pair both devices again. Doing this may remove any problems that may have been registered during the initial pairing.
---------------------------------------	--

4. TECHNICAL SUPPORT

If you encounter a problem with your product, please go to <http://ts.hercules.com> and select your language. From there you will be able to access various utilities (Frequently Asked Questions (FAQ), the latest versions of drivers and software) that may help to resolve your problem. If the problem persists, you can contact the Hercules products technical support service ("Technical Support"):

By email:

To reach our Technical Support via **email**, you must first register online on the <http://ts.hercules.com> website. The information that you provide will help our technicians to resolve your problem as quickly as possible.

Click on **Product Registration** and follow the instructions displayed onscreen.

If you have already registered your product, please enter your user info in the **Username** and **Password** fields, then click on **Login**.

By telephone (if you do not have Internet access):

United Kingdom	08450800942 Charged at local rate	Monday to Saturday from 8 a.m. to 7 p.m.
United States	1-866-889-5036 Free	Monday to Friday from 9 a.m. to 8 p.m. Saturday from 8 a.m. to 2 p.m. <i>(Eastern Standard Time)</i> Monday to Friday from 6 a.m. to 5 p.m. Saturday from 5 a.m. to 11 a.m. <i>(Pacific Standard Time)</i>
Canada	1-866-889-2181 Free	Monday to Friday from 9 a.m. to 8 p.m. Saturday from 8 a.m. to 2 p.m. <i>(Eastern Standard Time)</i> Monday to Friday from 6 a.m. to 5 p.m. Saturday from 5 a.m. to 11 a.m. <i>(Pacific Standard Time)</i>
Denmark	80887690 Free	Monday to Saturday from 9 a.m. to 8 p.m. <i>(English)</i>
Sweden	0200884567 Free	Monday to Saturday from 9 a.m. to 8 p.m. <i>(English)</i>
Finland	0800 9130 60 Free	Monday to Saturday from 10 a.m. to 9 p.m. <i>(English)</i>

Hours of operation and telephone numbers are subject to change. Please visit <http://ts.hercules.com> for the most up-to-date Technical Support contact information.

5. WARRANTY

Worldwide, Guillemot Corporation S.A. ("Guillemot") warrants to the consumer that this Hercules product will be free from material defects and manufacturing flaws for a period of two (2) years from the original date of purchase. Should the product appear to be defective during the warranty period, immediately contact Technical Support, who will indicate the procedure to follow. If the defect is confirmed, the product must be returned to its place of purchase (or any other location indicated by Technical Support).

Within the context of this warranty, the consumer's defective product will, at Technical Support's option, be either repaired or replaced. Where authorized by applicable law, the full liability of Guillemot and its subsidiaries (including for indirect damages) is limited to the repair or replacement of the Hercules product. The consumer's legal rights with respect to legislation applicable to the sale of consumer goods are not affected by this warranty.

This warranty shall not apply: (1) if the product has been modified, opened, altered, or has suffered damage as a result of inappropriate or abusive use, negligence, an accident, normal wear, or any other cause not related to a material defect or manufacturing flaw; (2) in the event of failure to comply with the instructions provided by Technical Support; (3) to software not published by Guillemot, said software being subject to a specific warranty provided by its publisher.

ADDITIONAL WARRANTY PROVISIONS

In the United States of America and in Canada, this warranty is limited to the product's internal mechanism and external housing. Any applicable implied warranties, including warranties of merchantability and fitness for a particular purpose, are hereby limited to two (2) years from the date of purchase and are subject to the conditions set forth in this limited warranty. In no event shall Guillemot Corporation S.A. or its affiliates be liable for consequential or incidental damage resulting from the breach of any express or implied warranties. Some States/Provinces do not allow limitation on how long an implied warranty lasts or exclusion or limitation of incidental/consequential damages, so the above limitation may not apply to you. This warranty gives you specific legal rights, and you may also have other legal rights which vary from State to State or Province to Province.

6. ENVIRONMENTAL CERTIFICATIONS AND RECOMMENDATIONS



At the end of its working life, this product should not be disposed of with standard household waste, but rather dropped off at a collection point for the disposal of Waste Electrical and Electronic Equipment (WEEE) for recycling.

This is confirmed by the symbol found on the product, user manual or packaging. Depending on their characteristics, the materials may be recycled. Through recycling and other forms of processing Waste Electrical and Electronic Equipment, you can make a significant contribution towards helping to protect the environment.

Please contact your local authorities for information on the collection point nearest you.

Disposal information

- 1) If the product features the symbol of a crossed-out wheeled trash bin, this means that the product conforms to the standards of European Directive 2002/96/EC.
- 2) All electrical and electronic products must be disposed of separately from household waste, by way of collection points designated by the government or local authorities.
- 3) The proper disposal of your old product will contribute to preventing any potential negative impact on the environment and health.
- 4) For more information on the proper way to dispose of your old product, please consult your local authorities, your waste disposal service or the store in which you purchased the product.

Trademarks

Hercules® is a registered trademark of Guillemot Corporation S.A. The Bluetooth® brand name and logo are registered trademarks of Bluetooth® SIG, Inc. All other trademarks and brand names are hereby acknowledged and are property of their respective owners. Illustrations not binding.

FCC STATEMENT

1. This device complies with Part 15 of the FCC Rules. Operation is subject to the following two conditions:
 - (1) This device may not cause harmful interference, and
 - (2) This device must accept any interference received, including interference that may cause undesired operation.
2. Changes or modifications not expressly approved by the party responsible for compliance could void the user's authority to operate the equipment.

NOTE: This equipment has been tested and found to comply with the limits for a Class B digital device, pursuant to Part 15 of the FCC Rules. These limits are designed to provide reasonable protection against harmful interference in a residential installation. This equipment generates, uses and can radiate radio frequency energy and, if not installed and used in accordance with the instructions, may cause harmful interference to radio communications. However, there is no guarantee that interference will not occur in a particular installation. If this equipment does cause harmful interference to radio or television reception, which can be determined by turning the equipment off and on, the user is encouraged to try to correct the interference by one or more of the following measures:

- Reorient or relocate the receiving antenna.
- Increase the separation between the equipment and receiver.
- Connect the equipment into an outlet on a circuit different from that to which the receiver is connected.
- Consult the dealer or an experienced radio/TV technician for help.

Declaration of conformity with EU directives

Hereby, GUILLEMOT CORPORATION declares that the **WAE-BTP02** device complies with the essential requirements and other relevant provisions of Directive 1999/5/EC. The declaration of conformity may be consulted at the following address:

http://www.hercules.com/certificates/wireless_speaker/DoC-BTP02.pdf



Hercules is a division of Guillemot Corporation.

Copyright

© Guillemot Corporation S.A. 2012. All rights reserved.

This publication may not be reproduced in whole or in part, summarized, transmitted, transcribed, stored in a retrieval system, or translated into any language or computer language, in any form or by any means, electronic, mechanical, magnetic, photocopying, recording, manual or otherwise, without the prior written permission of Guillemot Corporation S.A.